



# INSTALLATION INSTRUCTIONS HIGH OUTPUT SINGLE RAD FAN ASSEMBLY PART # 16919

Please read these instructions completely before beginning installation

### KIT CONTENTS

QTY.	DESCRIPTION	QTY.	DESCRIPTION
1	Fan Shroud Assembly	16	1/4-20 Lock Nuts
4	Angle Brackets	40	1/4" Flat Washers
1	Rubber Fan Shroud Seal		
16	1/4-20 x 3/4" Hex Bolts		

### TOOLS NEEDED

7/16" Open End Wrench  
7/16" Socket and Ratchet  
Standard Screw Driver or  
5/16" Nut Driver  
Drill  
5/32" Drill Bit  
12V Test Light  
Wire Stripper  
Crimping Tool

### Diagram #1

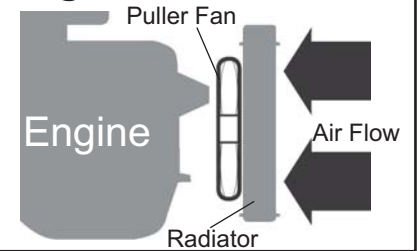

### IMPORTANT

This fan assembly is designed for PULLER APPLICATIONS ONLY Engine side of radiator. (See Diagram #1)

### MOUNTING OPTIONS

#### Diagram #2 Down Flow Radiator

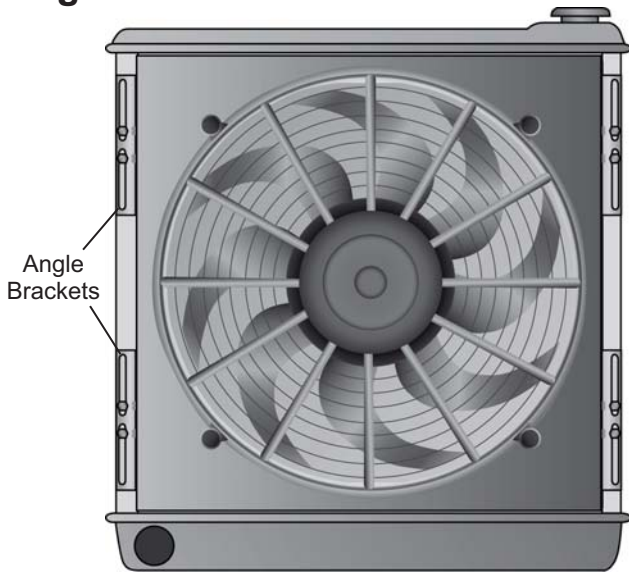

#### Cross Flow Radiator

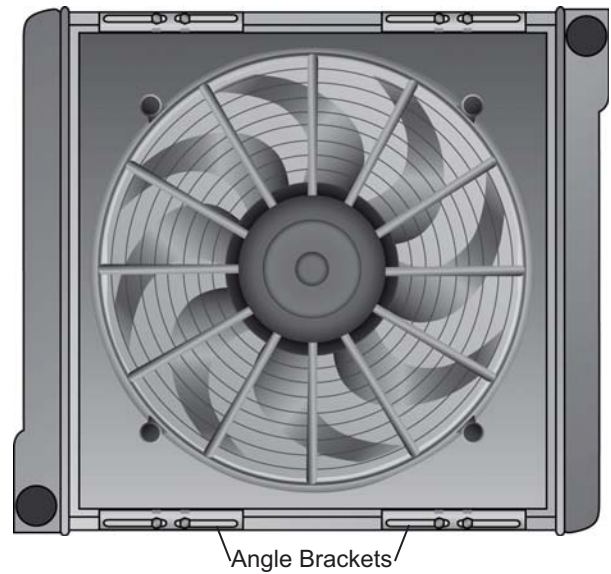

### Diagram #3

#### Option 1 Flush Mount

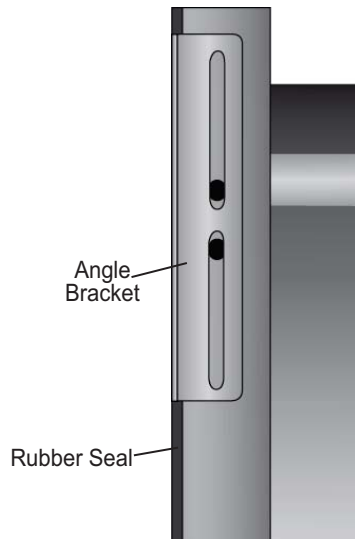

#### Option 2 Recessed Mount

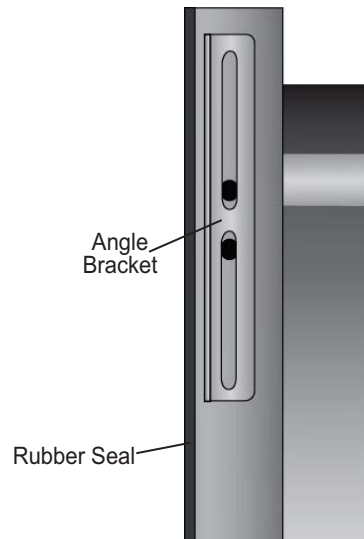

#### Adjustment Range

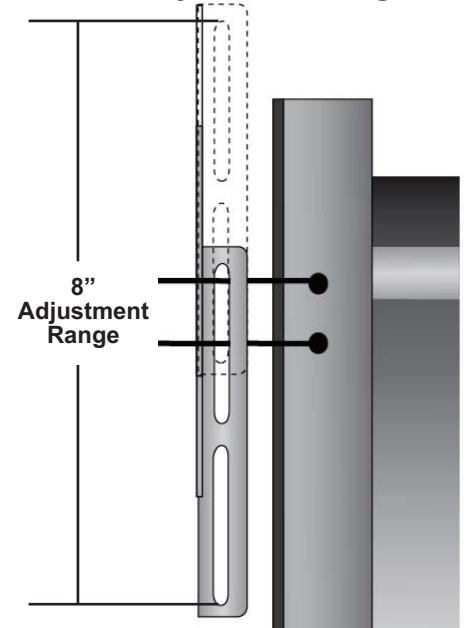

## INSTALLATION

1. Using a table or workbench, lay the Electric Fan Assembly on a flat surface, Electric Fan facing down.
2. Take the supplied Rubber Fan Shroud Seal and install it onto the bottom edge of the Fan Shroud Assembly. (See Diagram #4)
3. Cut off any excess Rubber.
4. Identify the four Angle Brackets, 1/4-20 x 3/4" Hex Bolts, 1/4" Flat Washers & 1/4-20 Lock Nuts.
5. Attach the Angle Brackets to the Shroud using two bolts per bracket. (See Diagram #5)

**Important:** Two 1/4" Flat Washers must be used between the Angled Brackets and the Shroud to avoid the rivet for full adjustment range.

**Note:** In some applications where the radiator flange is not right up against the fan shroud, longer bolts can be used to space the Angle Brackets. (See Diagram #6) Hardware not included!

6. Position the Electric Fan Assembly against the radiator in the desired location.
7. Using the remaining 1/4-20 x 3/4" Hex Bolts, 1/4" Flat Washers & 1/4-20 Lock Nuts, attach the Electric Fan Shroud Assembly to the radiator. (See Diagram #5)

**Note:** In some cases the radiator flange may have to be drilled for proper alignment.

**Diagram #4**

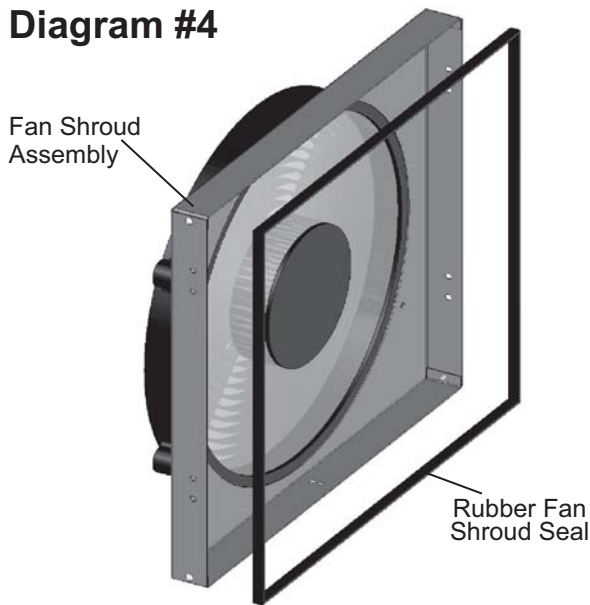

**Diagram #5**

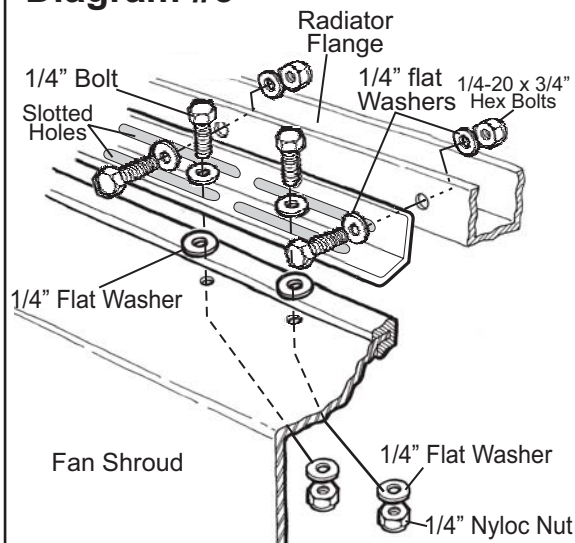

**Diagram #6**

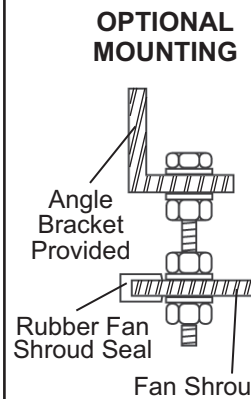

## WIRING

**Important:** The Electric Fan Assembly is built using a High Output two speed motor. If you choose to operate the fan using both speeds, two switching devices must be used.

**Reference Diagrams #7 & 8 on page 3**

## WIRING OPTIONS

There are a few options on how to activate (turn on) your new Electric Fan Assembly.

1. Manual Switch - Install a switch in the passenger compartment and turn on Electric Fan as desired.
2. Electric Fan Thermostat Switch
  - A. Adjustable Thermostat - Allows an adjustment range for you to determine optimal turn on temperature.
  - B. Pre Determined Temperature - Thermostat has a pre determined temp. from the factory that determines turn on temp.

We recommend using two thermostats therefore activating the low speed at an earlier temperature than the high speed. Please visit [www.derales.com](http://www.derales.com) for available thermostat options or visit your local retailer.

**Important:** When purchasing a thermostat always consider the maximum amp draw. Some thermostats are not designed to properly handle higher amperage fans.

**Note:** When installing the Electric Fan with a Thermostat always follow manufacturer's instructions for specific details. In some cases you will not need the supplied relay harness.

## RELAY WIRE HARNESS MOUNTING (NOT SUPPLIED)

1. Taking into consideration fan placement and wire routing requirements, choose a convenient location. Avoid mounting near HOT engine components.
2. Using the relay bracket as a template, mark and drill a 5/32" hole in the proper location.
3. Using the #10 Sheet Metal Screws (not supplied), install the relay/wire harness.

(Page 2)

**TIPS:** Always disconnect vehicles battery before beginning installation involving your vehicles electrical system. All 12 Volt Positive leads require the use of the appropriate fuse load rating to avoid damage to your vehicles electrical system. Always insist on using only high quality components (wire, connectors, and switch) for use in installation of your new Derale Electric Fan Assembly.

## **WIRING INSTALLATION USING RELAY (NOT SUPPLIED)**

**RED Wire** - Attach to the Positive side of Battery (+)

**BLACK Wire** - Attach to a good Chassis ground (-)

**BLUE Wire** - Reference electric Fan below.

**ORANGE Wire** - Attach to a 30 Amp fused Circuit (Fuse not included), Reference the wiring options below for connections on orange wire after the fuse

**YELLOW Wire** - Attach to (+) 12V Switched Power (Thermostat or Manual Switch)

**GREEN Wire\*** - (OPTIONAL) Attach to the Positive feed from the A/C Clutch

\*This wire will allow you to turn on the Electric Fan every time the vehicles air conditioning is turned on. If you do not wish to use this option, please disregard the Green wire.

### **USING HIGH SPEED ONLY (See Diagram #7)**

**BLACK Wire** - Attach to a good Chassis ground (-)

**Grey Low Speed Wire** - Attach to the Orange positive (+) fan wire on the relay wire harness.

**Brown High Speed Wire** - Attach to the Blue positive (+) fan wire on the relay wire harness.

### **USING BOTH LOW & HIGH SPEEDS (See Diagram #8)**

**BLACK Wire** - Attach to a good Chassis ground (-)

**Grey Low Speed Wire** - Attach to 12V Switched Power (Manual Switch or Thermostat).

**Brown High Speed Wire** - Attach to the Blue positive (+) fan wire on the relay wire harness.

**Important:** Both Low speed & High speed wires must have power for high speed function to work

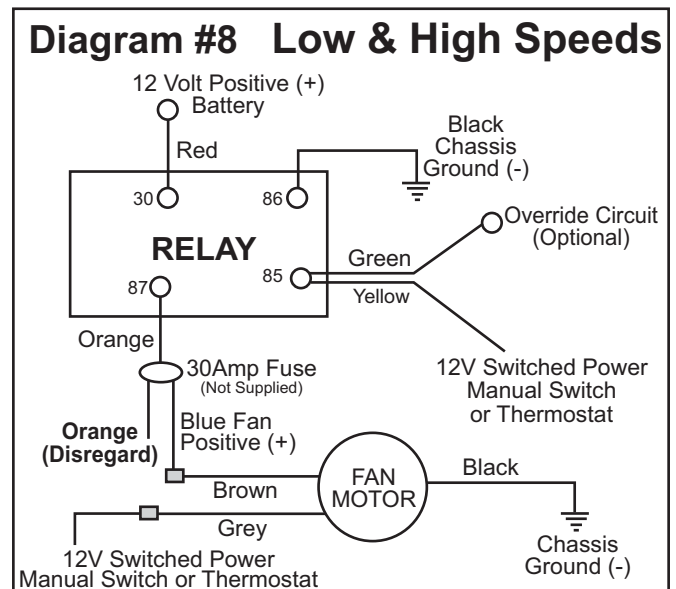
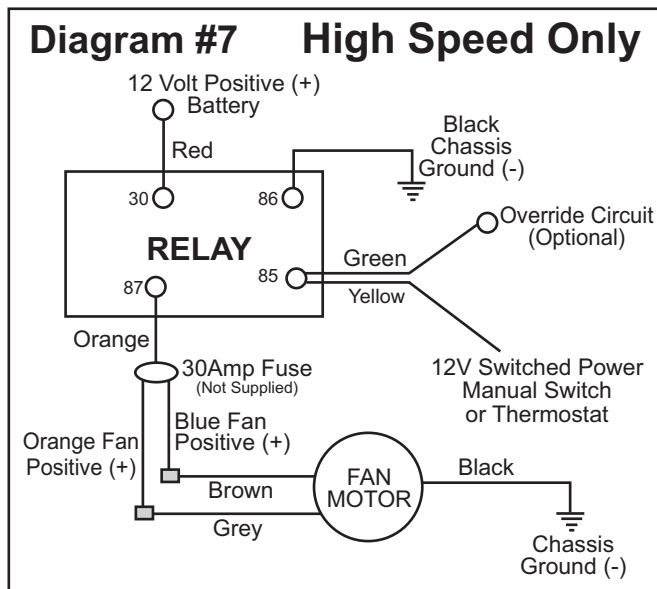

(Page 3)

**Warning:** Installation of accessories should only be undertaken by those with mechanical knowledge and are familiar with working on vehicles. Always use eye protection (goggles, safety glasses or shield). Park the vehicle in a well lit area, on level ground and apply the parking brake. Only work on a cold vehicle that has been sitting overnight, failure to do so will result in severe burns and injury. Before starting the vehicle, make sure no tools or any other items are left under hood that could interfere with or be drawn into moving parts of the engine. Failure to follow instructions can lead to severe damage and personal injury.