



INSTALLATION INSTRUCTIONS OIL FILTER RELOCATION KIT PART # 15781

Please read these instructions completely before beginning installation

KIT CONTENTS

QTY.	DESCRIPTION	QTY.	DESCRIPTION
1	Spin-On Adapter	2	1/2" NPT Plug
1	Ports Up Filter Mount	4	1/2" NPT x 1/2" Hose Barb
1	O-ring (Spin-On Adapter)	4	Hose Clamps
1	3/4-16 Filter Nipple	3	#14 Sheet Metal Screws
10ft.	1/2" Hose		

TOOLS NEEDED

7/8" Open End Wrench
Standard Screw Driver
1/8" Allen Wrench
Drill
3/16" Drill Bit
Teflon Tape

OIL FILTER CHART

BRAND	PART #
AC	PF2
Fram	PH8A
Motorcraft	FL1A
Purolator	PER1A

IMPORTANT

The new Filter Mount is designed to accept a 3/4-16 oil filter (Typical Ford filter) Use Derale Part # 13092 or reference Oil Filter chart.

PRE-INSTALLATION

1. Remove the factory oil filter and clean the oil filter landing surface on the engine block.
2. After determining the orientation of the Spin-on Adapter, using Teflon Tape or suitable sealant, install two 1/2" NPT x 1/2" Hose Barb fittings onto the correct "IN" and "OUT" ports on the Spin-on Adapter.
3. Take the two 1/2" NPT Plugs provided, using Teflon Tape or suitable sealant; install them in the remaining ports on the Spin-on Adapter.
4. Take the remaining two 1/2" NPT x 1/2" Hose Barb fittings, using Teflon Tape or suitable sealant; install them onto the Ports-up Filter Mount.

SPIN-ON ADAPTER INSTALLATION

1. Apply a light coat of oil onto the O-ring.
2. Take the O-ring and install into the groove on the Spin-On Adapter.
3. Install onto the engine. (See Diagram #1)
4. Hand Tighten with the same force used in tightening a factory oil filter.

FILTER MOUNT INSTALLATION

1. Choose a convenient location for the Ports-Up Filter Mount. Make sure there is enough space for future servicing of the oil filter. Suggested Locations: Firewall, Radiator Support, Fender well. (See Diagram #2)
2. Take the 3/4-16 Filter Nipple supplied, making sure the shorter end of threads is installed onto the Ports-Up Filter Mount.
3. Using the filter mount as a template, mark & drill three 3/16" holes.
4. Using the #14 Sheet Metal Screws provided, install the Ports-Up Filter Mount onto the vehicle.

Hose Routing

1. Using the Hose Clamps provided, attach both ends of the 1/2" Hose provided to the hose barb on the installed Spin-On Adapter forming a loop. (Apply a thin coat of oil to the Hose Barbs so the hose slips on easily.)
2. Carefully route hose over to the Ports-Up Filter Mount.
Note: Keep hoses away from sharp edges, moving parts and exhaust. Do not bend hose sharper than a 5" radius.
3. Cut the hose to the proper length.
4. Using the Hose Clamps provided, attach the hose coming from the OUT on the Spin-On Adapter to the IN on the Ports-Up Filter Mount.
5. Using the Hose Clamps provided, attach the hose coming from the IN on the Spin-On Adapter to the OUT on the Ports-Up Filter Mount.
6. Apply a light coat of oil onto the o-ring of your new oil filter and install on the filter mount.

VEHICLE TESTING

1. Start the engine and quickly check all connections for leaks.
2. Turn-off the engine and check the oil.
3. Add oil as needed.

Diagram #1

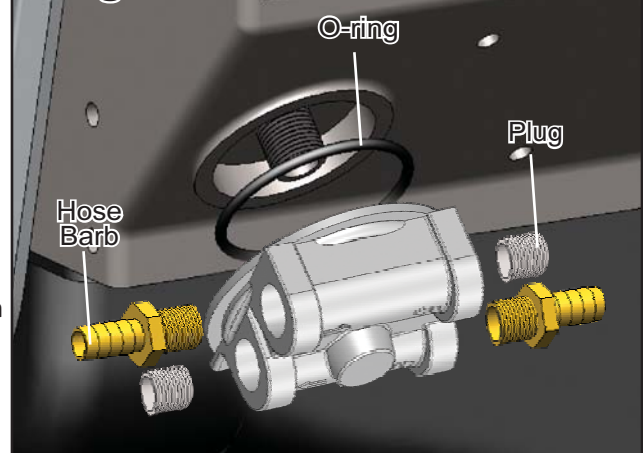

Diagram #2

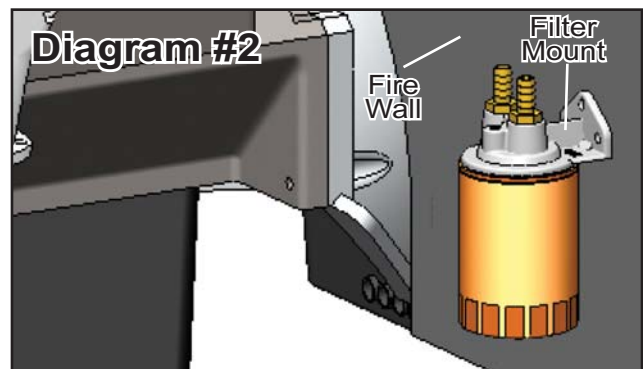
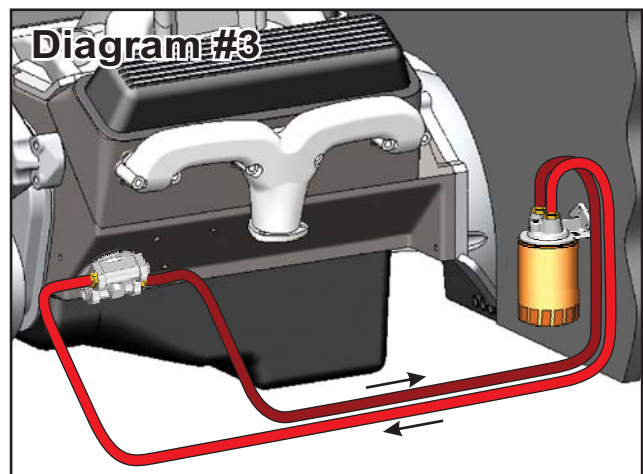

Diagram #3



Warning: Installation of accessories should only be undertaken by those with mechanical knowledge and are familiar with working on vehicles. Always use eye protection (goggles, safety glasses or shield). Park the vehicle in a well lit area, on level ground and apply the parking brake. Only work on a cold vehicle that has been sitting overnight, failure to do so will result in severe burns and injury. Before starting the vehicle, make sure no tools or any other items are left under hood that could interfere with or be drawn into moving parts of the engine. Failure to follow instructions can lead to severe damage and personal injury.