

ARB **BASE RACK**

FITTING INSTRUCTION

Part Number: Suits BASE RACK:
17920020 **1770040**
17920010 **1770060 / 1770070**

Product Description: **BASE RACK fitting kit suits FJ Cruiser**

WARNING

NOTE THE FOLLOWING:

- ◆ Vehicle accessories which are not properly fitted can be dangerous.
- ◆ Please read these instructions carefully prior to fitting, and comply with the instructions at all times
- ◆ If in any doubt please contact your nearest ARB state office or the stockist from whom it was purchased.
- ◆ Do not use this product for any vehicle make or model, other than those specified by ARB.
- ◆ This product or its fixing must not be modified in any way.
- ◆ The installation of this product may require the use of specialized tools and/or techniques
- ◆ It is recommended that this product is only installed by trained personnel
- ◆ These instructions are correct as at the publication date. ARB Corporation Ltd. cannot be held responsible for the impact of any changes subsequently made by the vehicle manufacturer
- ◆ During installation, it is the duty of the installer to check correct operation/clearances of all components
- ◆ Work safely at all times
- ◆ Unless otherwise instructed, tighten fasteners to specified torque
- ◆ Check bolt torque after 500km & at regular service intervals

ARB 4x4 ACCESSORIES

Corporate Head Office

42-44 Garden St
Kilsyth, Victoria
AUSTRALIA 3137

Tel: +61 (3) 9761 6622
Fax: +61 (3) 9761 6807

Australian enquiries
North & South American enquiries
Other international enquiries

sales@arb.com.au
sales@arbusa.com
exports@arb.com.au

www.arb.com.au

SAFETY

NET PAYLOAD FOR YOUR BASE RACK

The net payload for your BASE RACK is calculated by subtracting the weight of the BASE RACK and the vehicle mounting kit from the vehicle's roof capacity. The table below gives the BASE RACK net payload for fitting kits 17920020 & 17920010, using the vehicles maximum vehicle roof capacity. The vehicle's roof load capacity may vary between models and driving conditions. Refer to vehicle owner's manual for model and condition specific roof load capacities.

Kit	BASE RACK	Vehicle roof capacity* (kg/lb)	BASE RACK + mount kit (kg/lb)	BASE RACK net payload (kg/lb)
17920020	1770040	100 / 220	33 /73	67/147
17920010	1770060	100 / 220	19/42	81/178
17920010	1770070	100 / 220	21/46	79/174

* Maximum roof load capacity. Refer to vehicle owner's manual for model and condition specific roof load capacities.

It is important to follow the listed usage instructions;

- ◆ Maximum load per BASE RACK beam is 25kg.
- ◆ Load must be evenly distributed and adequately secured.
- ◆ Any weight carried on the roof of the vehicle will adversely affect its handling, particularly in cornering or in a cross-wind, the vehicle should therefore be driven with increased discretion.
- ◆ Regularly check the tightness of the securing clamps and the security of the load.
- ◆ Attention is directed to statutory requirements regarding maximum permissible projections from vehicles.

All bolts should be checked prior to touring to ensure the BASE RACK is fastened correctly

GENERAL CARE AND MAINTENANCE

By choosing an ARB BASE RACK, you have bought a product that is one of the most sought after 4WD products in the world. Your BASE RACK is a properly engineered, reliable, quality accessory that represents excellent value. To keep your BASE RACK in original condition it is important to care and maintain it following these recommendations:

- As part of any pre-trip preparation, or on an annual basis, it is recommended that a thorough visual inspection of the BASE RACK is carried out, making sure that all bolts and other components are torqued to the correct specification. Replace any components as necessary.

Please contact local Authorised ARB Stockist if you would like to have this service carried out on your behalf.

FITTING REQUIREMENTS

REQUIRED TOOLS FOR FITMENT OF PRODUCT:

10mm spanner x 2	13mm spanner x 1
Allen key set	Torx key set
Pen/pencil	Socket set
Tape measure	

NOTE: 'WARNING' notes in the fitting procedure relate to OHS situations, where to avoid a potentially hazardous situation it is suggested that protective safety gear be worn or a safe work procedure be employed. If these notes and warnings are not heeded, injury may result.

FASTENER TORQUE SETTINGS:

SIZE	Torque Nm	Torque lbft
M6	9Nm	7lbft
M8	22Nm	16lbft

PARTS LISTING - BASE RACK fitting kit

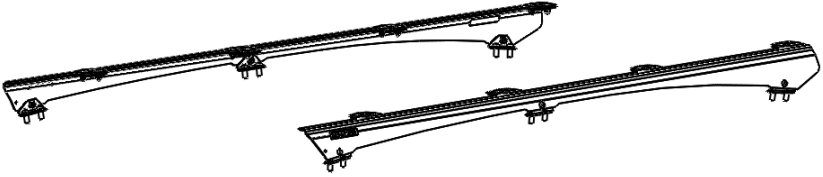
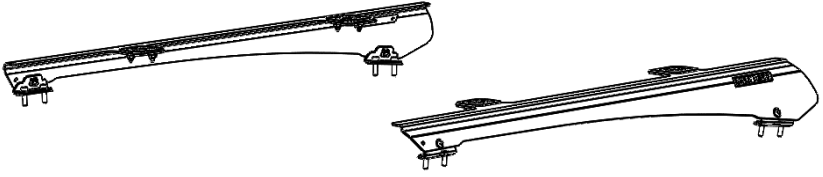



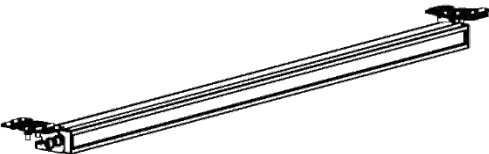

PART NUMBER	SUITS BASE RACK	QTY	DIAGRAM
17920020	1770040	1	
17920010	1770060 / 1770070	1	

Air Deflector and Base Rack Light Bar

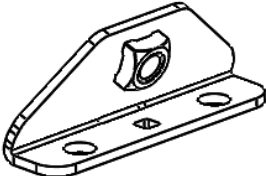
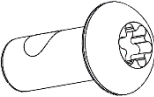
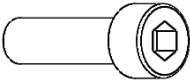

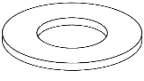
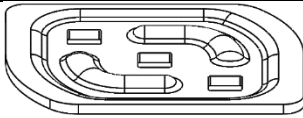
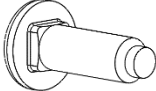

An air deflector or BASE RACK Light Bar should be fitted beneath the front edge of the BASE RACK. Refer to the table below for the correct part number. If fitting the light bar in front of the BASE RACK, an Air Deflector should also be fitted. Refer to the instructions provided with these products for further details.

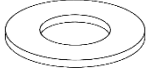
		PART NUMBER	BASE RACK FITTING KIT
AIR DEFLECTOR		17920040	17920020
BASE RACK LIGHT BAR		17920030	17920010

PARTS LISTING 17920020

PART NO.	PICTURE	QTY	DESCRIPTION
APPLICATION – MOUNTING BRACKETS TO ROOF			
3750584L		1	BLADE BRACKET FJ CRUISER 2125 LH
3750584R		1	BLADE BRACKET FJ CRUISER 2125 RH
3750660		6	MOUNTING BRACKET W/ WELD NUT
6151924		6	M8 X 1.25 X20 BUTTON HEAD TORX - BLK
6151184		12	M8 X 1.25 X 30MM SOCKET HEAD CAP
4584415		12	M8 WASHER FLAT - BONDED
5846403		6	RUBBER PACKER
6151934		1	TORX ALLEN KEY
4581085		6	M8 WASHER FLAT - BLACK
APPLICATION – BASE RACK TO MOUNTING BRACKETS			
3195184		8	M8 STUD PLATE
6151921		16	M8 STUD - BLACK
6151212		16	M8 X 1.25 NYLOC NUT - BLACK
4581085		16	M8 WASHER FLAT - BLACK

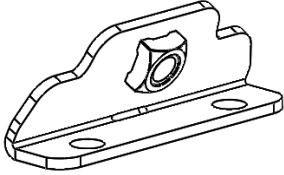
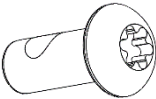
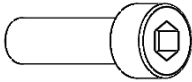
PARTS LISTING 17920010

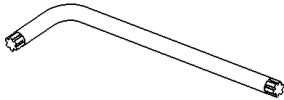
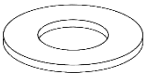
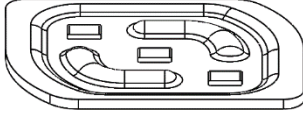
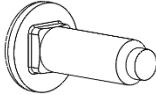
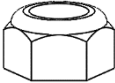
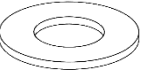
PART NO.	PICTURE	QTY	DESCRIPTION
APPLICATION – MOUNTING BRACKETS TO ROOF			
3750585L		1	BLADE BRACKET FJ CRUISER 1255 LH
3750585R		1	BLADE BRACKET FJ CRUISER 1255 RH
3752748		4	MOUNTING BRACKET W/ WELD NUT
6151924		4	M8 X 1.25 X20 BUTTON HEAD TORX - BLK
6151184		8	M8 X 1.25 X 30MM SOCKET HEAD CAP
4584415		8	M8 WASHER FLAT - BONDED
5846403		4	RUBBER PACKER
6151934		1	TORX ALLEN KEY
4581085		4	M8 WASHER FLAT - BLACK
APPLICATION – BASE RACK TO MOUNTING BRACKETS			
3195184		4	M8 STUD PLATE
6151916		8	M8 X 25 STUD - BLACK
6151212		8	M8 X 1.25 NYLOC NUT - BLACK
4581085		8	M8 WASHER FLAT - BLACK

BEFORE STARTING, READ ALL STEPS OF THE INSTRUCTIONS CAREFULLY AND CHECK ALL PARTS

STEP 1: REMOVAL OF CHANNEL COVERS

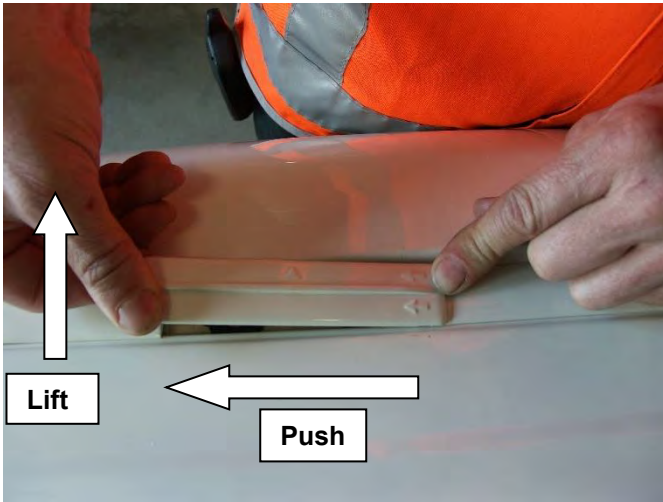

1. Remove the plastic covers from the roof of the vehicle, just the rear four if fitting part No 17920010 or all six if fitting part No 17920010.

Hint: To remove the plastic covers push in the direction of the arrows and carefully lift the opposite end.



2. Underneath each of the plugs is a pressed bracket. Remove it and all the fasteners.
3. Thoroughly clean the sealing surface in the base of the channel where the supplied rubber seal and mounting bracket will sit.

NOTE: Keep the factory bolts, brackets and plastic covers in a safe place so that they can be re-fitted if you wish to remove the roof rack.

STEP 2 – ATTACH MOUNTING BRACKETS TO ROOF

17920020 x6

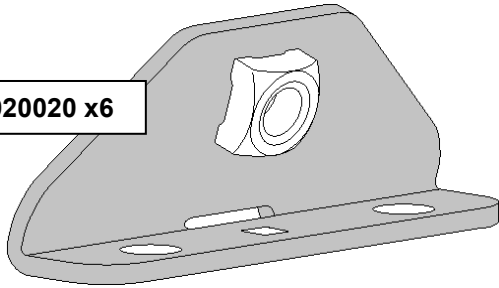

17920010 x4

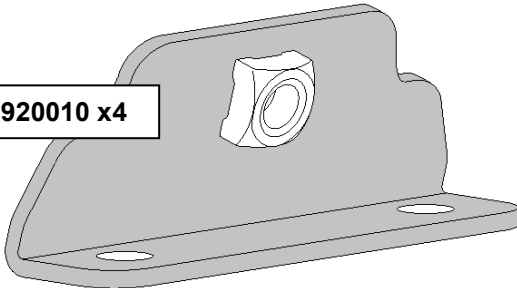

4. The BASE RACK being fitted will determine the number of mounting brackets contained in the fitting kit.

Fitting kit 17920020 for BASE RACK 1770040 contains 6 mounting brackets.

Fitting kit 17920010 for BASE RACK 1770060 / 1770070 contains 4 mounting brackets.

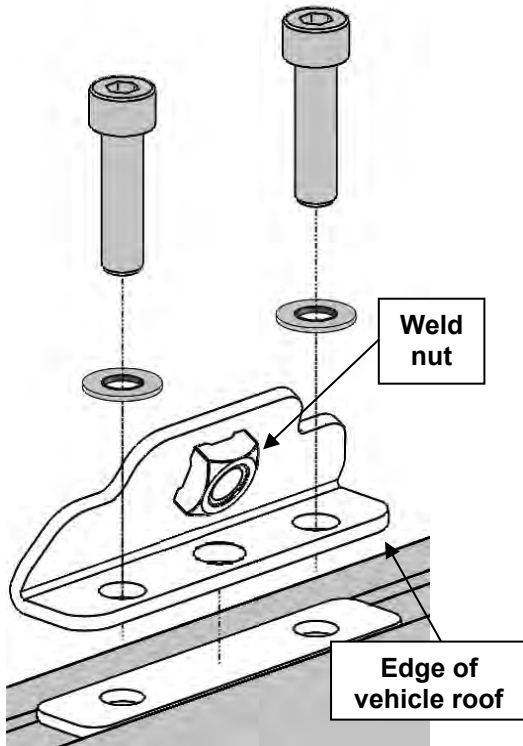

5. Place a rubber packer over each of the sets of holes in the roof channels
6. Position each mounting bracket so the weld nut is facing towards the centre of the vehicle. Attach each bracket to the roof mounting points using M8 Socket head screws and M8 Bonded washers. The image to the right shows the 17920010 (x4) mounting brackets.

Tighten screws to specified torque

 Torque M8 to 22Nm

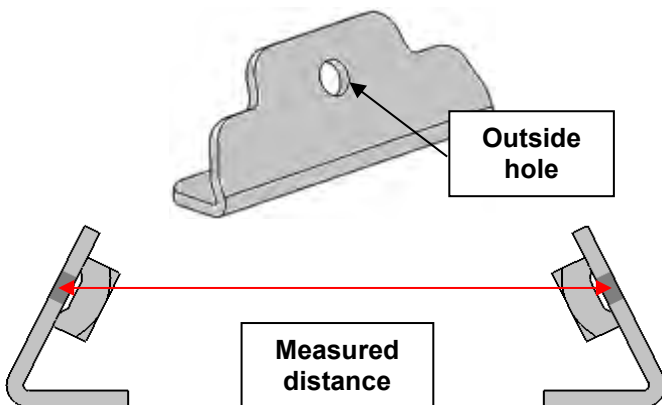

4. Using a tape measure, measure across the vehicle between the middle of the hole on the outside face of the front and rear set of mounting brackets. Make a note of each measurement.

Position	Distance
Front	
Rear	

STEP 3 – ASSEMBLE THE BASE RACK

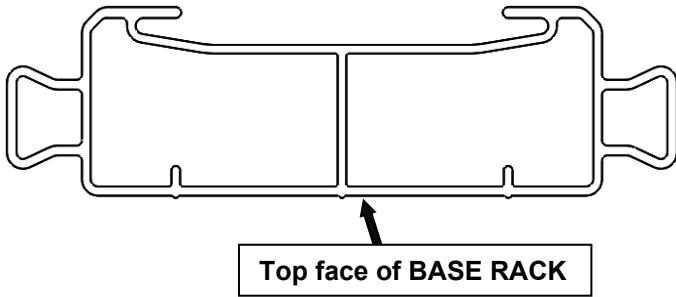

5. Place the BASE RACK face down on a clean flat surface. Provide protection to the top face of BASE RACK to avoid marking of surfaces

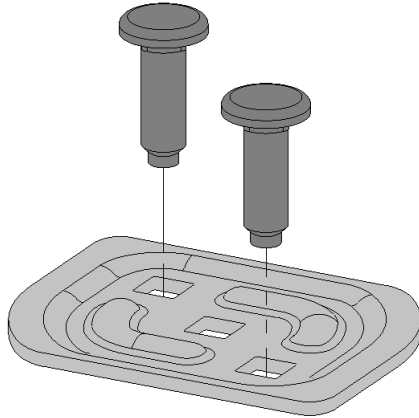

6. Insert 2, M8 x 25 Studs into each of the Stud Plates as shown.

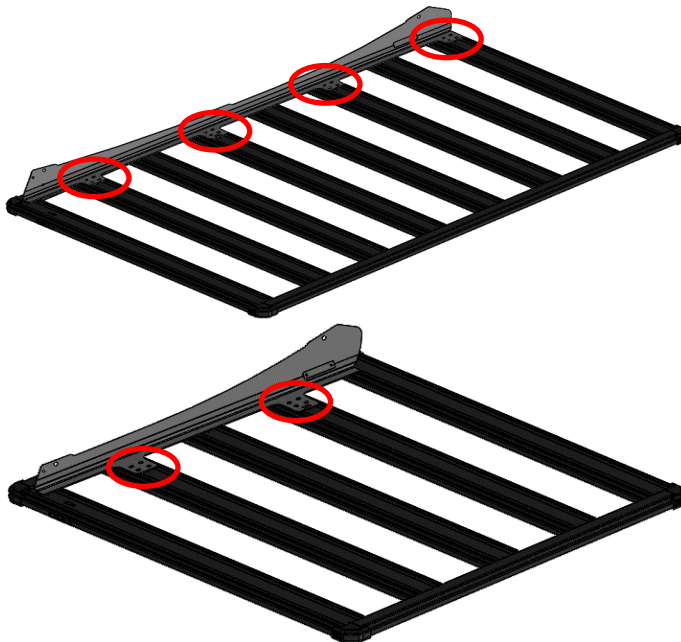

7. Check the position of the mounting plates (circled in image) on the blade brackets in relation to the channels on the BASE RACK.

BASE RACK 1770040 shown above left

BASE RACK 1770070 shown below left. 1770060 uses the same channels.

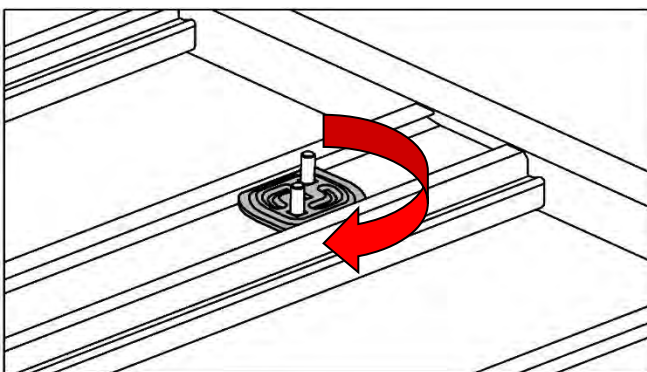

8. Insert the previously assembled stud plates into the correct BASE RACK channels. Rotate the plates 90 degrees.

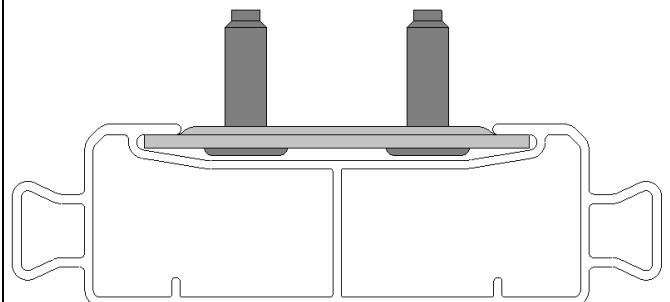

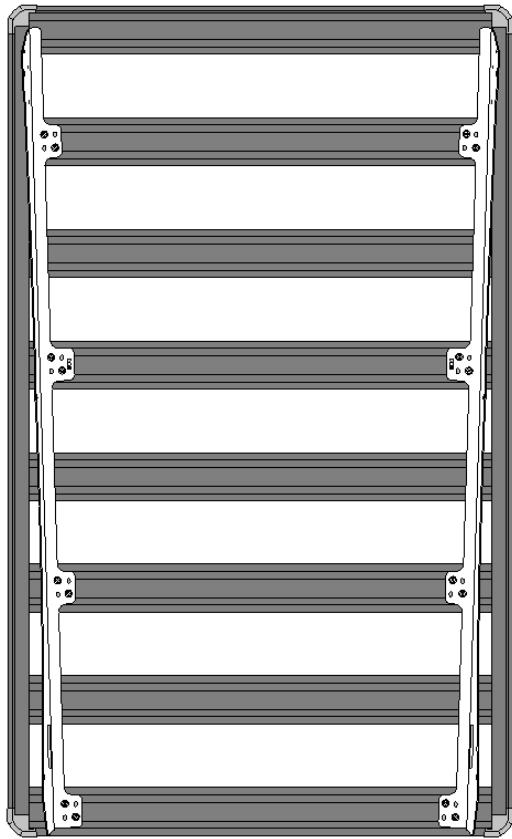

9. Flip the blade brackets over so they are upside down and carefully place on top of the BASE RACK. When doing so ensure the coach bolts in the stud plates go through the slots. Then secure the blade brackets to the BASE RACK using M8 flat washers and nyloc nuts.

Do not fully tighten, allowing each blade to move within the BASE RACK stud plate channel.

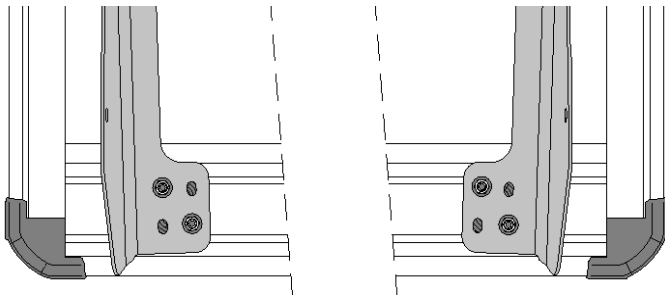
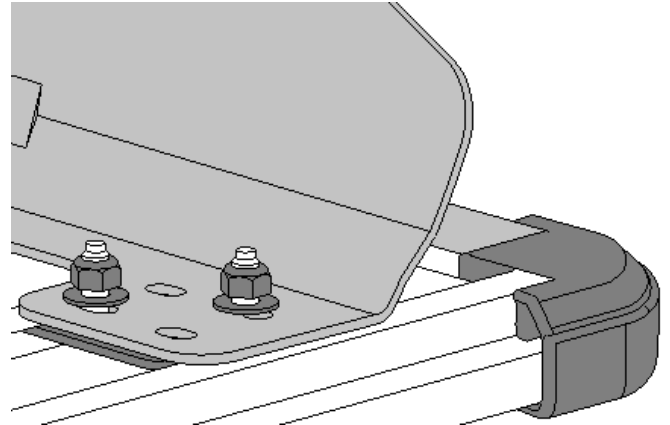

10. Using the previously recorded measurements, adjust the location of the blade bracket on the BASE RACK.

Ensure the distance between the blade bracket and the edge of the BASE RACK is the same on both sides. Fully tighten all M8 Nyloc nuts



Torque M8 to 22Nm

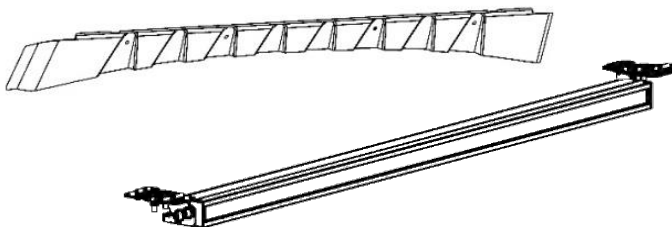

11. If fitting an air deflector or BASE RACK lightbar it should be fitted to the BASE RACK at this point. Refer to instructions provided with the air deflector or BASE RACK for fitting details.

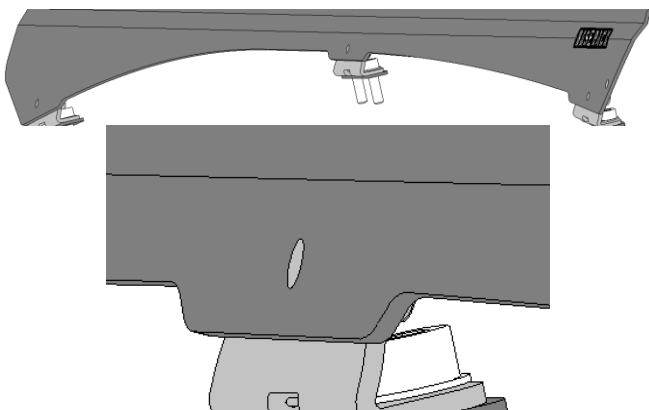

12. With assistance, carefully place the BASE RACK on the vehicle so the inside of the blade brackets rests on the outside of the mounting brackets. The entire BASE RACK assembly should be clear of the vehicle roof. All mounting holes/slots should align closely.

Note: Place protective material on roof to reduce the risk of accidental damage to vehicle when mounting the BASE RACK to the vehicle.

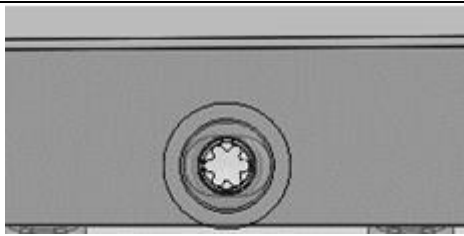

13. Confirm BASE RACK is correctly aligned to vehicle. If it is not it is recommended to remove the BASE RACK from the vehicle roof and repeat the mounting process from the measurement step.

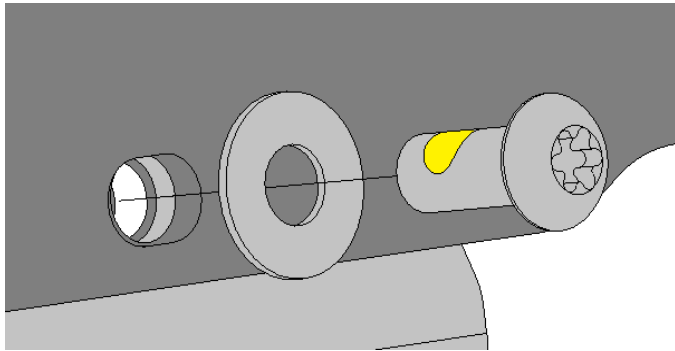

14. Use the M8 Button head Torx screws and M8 Black washers to secure the BASE RACK to the roof mounting brackets. Tighten all screw to the specified torque.



Torque M8 to 22Nm

Kit 17920020 & BASE RACK 1770040 shown.

