

# S5206

1999-2004 Ford F250/F350, 6.8L V10,  
Cat-Back, 4.0" Single Side

# MBRP®

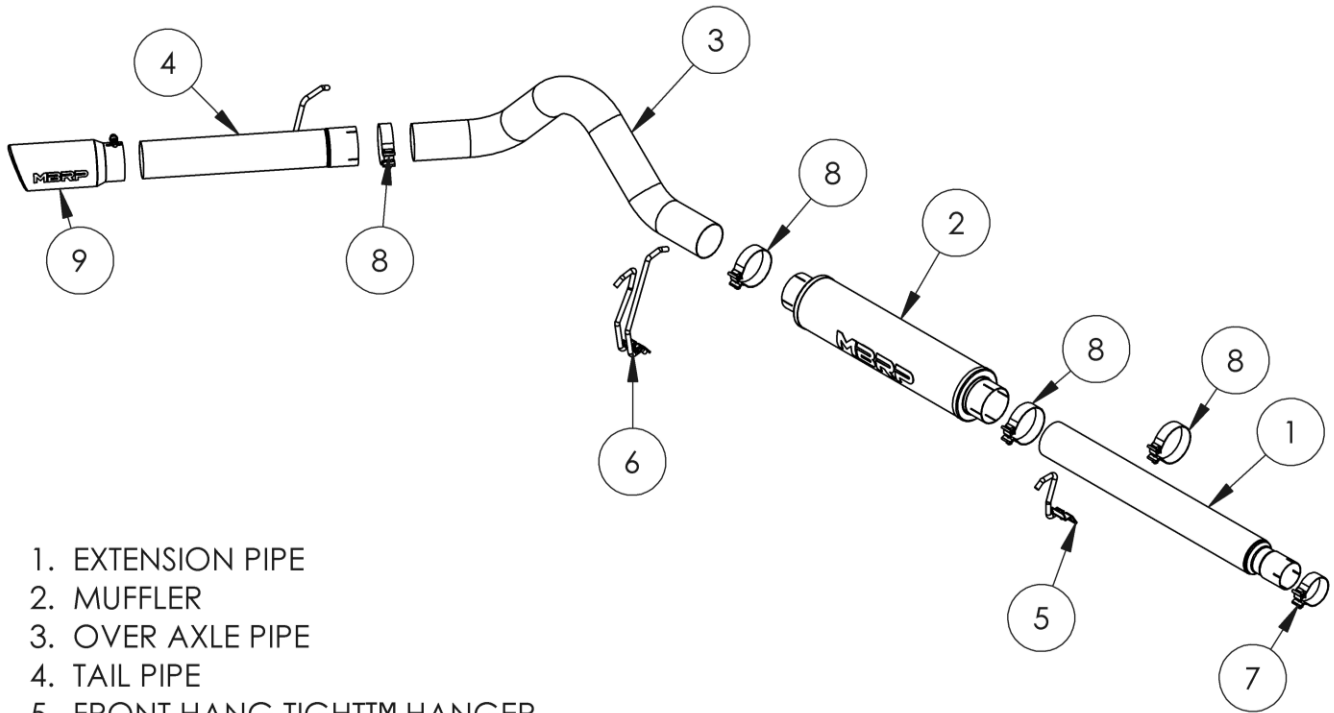

1. EXTENSION PIPE
2. MUFFLER
3. OVER AXLE PIPE
4. TAIL PIPE
5. FRONT HANG TIGHT™ HANGER
6. REAR HANG TIGHT™ HANGER
7. 3" BAND CLAMP
8. 4" BAND CLAMP (3PCS)
9. EXHAUST TIP

## PLEASE READ BEFORE STARTING INSTALLATION

While MBRP has made every effort to ensure that all components of this system are of superior quality and properly packaged, it is the installer's responsibility to ensure the following before removal of the factory exhaust:

- that ALL components shown above are present.
- that ALL mating components fit together.
- that there are no damaged components.
- that the system you have purchased is appropriate for your vehicle year, model and configuration.
- that the system will not interfere with any modifications previously installed or planned.
- that you have read and understand these instructions.

If you have any questions or are uncertain about any aspect of the installation of this system to your vehicle please contact your dealer before commencing installation.

# MBRP®

1999-2004, Ford, F250/F350, 6.8L, V10



Figure 1

## Removal of stock system:

1. Loosen the nut on the band clamp located behind the catalytic converter using a 15mm wrench or socket. **See Figure 1.**
2. Remove the muffler and tail pipe from the OEM rubber hangers. On '03 and '04 trucks remove bottom shock bolt of passenger side shock to remove system in one piece. Separate the stock exhaust from the slip joint located behind the catalytic converter. Remove the muffler and tail pipe from under the truck. Re-install the shock bolt.

## Installation of MBRP Inc. Performance Exhaust:

1. Hang the **Rear Hang Tight™ Hanger** (See Figure 3 for Hang Tight™ instructions) in the factory rubber isolators located right above where the rear of the factory muffler was located. Temporarily hang the **Muffler** in place and measure from the front of the **Muffler** to the short length of factory pipe attached to the rear of the catalytic converter. This will give you the required length for the extension pipe.
2. Cut the **Extension Pipe** to the required length and attach it to the factory pipe behind the catalytic converter, securing it using the provided **3" Band Clamp**. **See Figure 1.**
3. Install the **Muffler** over the **Extension Pipe** securing them with one of the provided **4" Band Clamps**. The **Front Hang Tight™ Hanger** is used on the **Extension Pipe** and installed into the OEM rubber hanger position. Install the **Rear Hang Tight™ Hanger** into the two OEM rubber hangers located above the outlet of the Muffler.

Figure 2

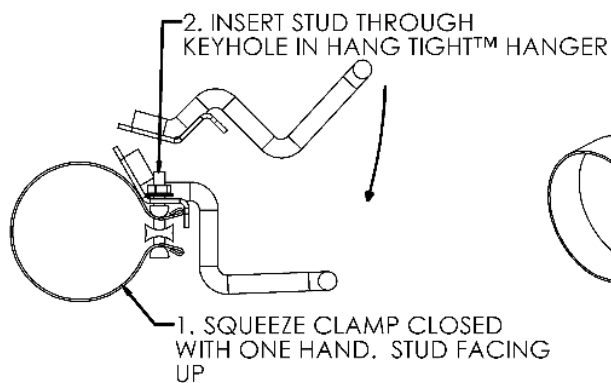

3. ROTATE HANG TIGHT™ HANGER TO SEAT THREADED STUD IN SLOT, BE SURE THE NUT IS ABOVE THE BRACKET

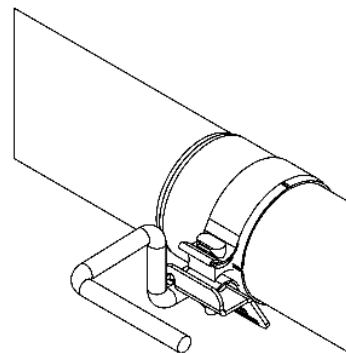
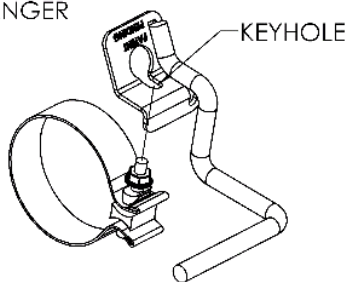

AS INSTALLED ON VEHICLE

Figure 3

# MBRP<sup>®</sup>

4. Install the **Over-Axle Pipe** from the rear of the truck, over the axle and attach to the **Muffler** outlet, securing it using the **Rear Hang Tight™ Hanger**.
5. Install the **Tail Pipe** from the rear of the truck, attach to the **Over-Axle Pipe** outlet. Install the tail pipe hanger into the OEM hanger to complete, securing it using the remaining **4" Band Clamp**.
6. Tighten all hardware and clamps, starting at the front and working rearward to secure the system. Check along the full length of the exhaust system to ensure there is adequate clearance for fuel lines, vent lines, brake lines, frame, bodywork, suspension, and any wiring, etc. If there is any interference detected, relocate, or adjust to provide adequate clearance. Ensure all clamp connections are secure and components are unable to rotate or slide. Band clamps require approximately 45 lb-ft (60 N-m) of torque. Verify clearances, system security and band clamp torque after 30-60 miles (50-100 km) of driving.

**Congratulations!** You are ready to begin experiencing the improved power, sound and driving excitement of you MBRP Inc. Performance Exhaust system. We know you will enjoy your purchase.