

# AT-9524AS

ACTIVE EXHAUST, SLIP-ON, DUAL-OUT  
2020-UP POLARIS RZR PRO XP  
2022-UP POLARIS RZR TURBO R  
2025-UP POLARIS RZR TURBO S

# MBRP

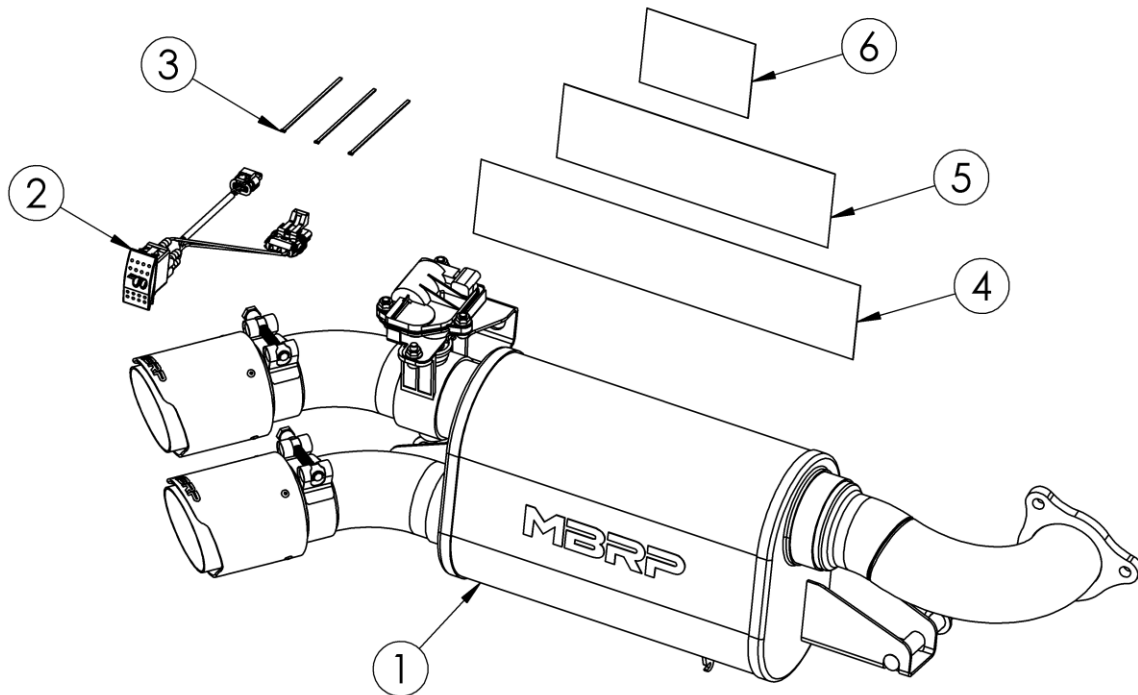

ITEM NO.	DESCRIPTION	QTY.
1	MUFFLER ASSEMBLY	1
2	SWITCH ASSEMBLY	1
3	CABLE TIE	3
4	FOIL TAPE - 4"	1
5	FOIL TAPE - 10"	1
6	FOIL TAPE - 14"	1

## PLEASE READ BEFORE STARTING INSTALLATION

While MBRP Ltd. has made every effort to ensure that all components of this system are of superior quality and properly packaged, it is the installer's responsibility to ensure the following before removal of the factory exhaust:

- that ALL components shown above are present.
- that ALL mating components fit together.
- that there are no damaged components.
- that the system you have purchased is appropriate for your vehicle year, model and configuration.
- that the system will not interfere with any modifications previously installed or planned.
- that you have read and understand these instructions.

If you have any questions or are uncertain about any aspect of the installation of this system to your vehicle please contact your dealer before commencing installation.

# MBRP

## Removal of Stock Exhaust:



Figure 1

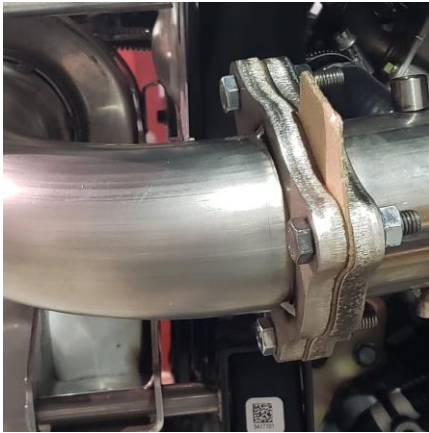

Figure 2

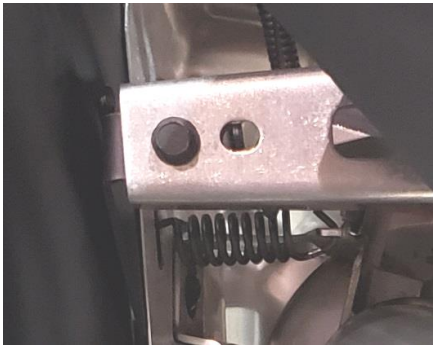

Figure 3



Figure 4

\* **Retain all factory hardware for final installation.**

1. Remove the rear panel covering the muffler. **Refer to Figure 1.**
2. Remove the three (3) nuts securing the muffler inlet to the exhaust pipe.
3. Remove the upper (driver-side near muffler outlet) and lower springs securing the muffler to the vehicle.
4. Remove the muffler by sliding the hangers out of the rubber isolators. Leave the gasket on the vehicle exhaust pipe.

## Installation of MBRP Exhaust:

1. Slide the hanger rods into the rubber isolators on the vehicle and mate the **Muffler Assembly** inlet pipe to the end of the exhaust pipe. **Refer to Figure 2.**
2. Secure the **Muffler Assembly** by attaching the previously removed spring at the top location. **Refer to Figure 3.**
3. Re-install the lower spring to the tab on the muffler body.
4. Secure the inlet using the stock nuts that were removed previously.

NOTE: The valve **Switch Assembly** is mounted into one of the open switch slots in the center dash panel and is connected to the exhaust valve and the auxiliary PULSE bar (power).

5. Remove the cover from the desired switch slot in the dash panel. The wiring will feed through this opening to the two connection locations. **Refer to Figure 4.**
6. Route the power connection (shorter cable) straight ahead from behind the dash and up, into the PULSE bar compartment (accessed by removing the panel at the top of the hood). Connect it to an unused accessory terminal on the PULSE bar.

NOTE: The wiring to the exhaust valve is routed down from behind the dash, and back through the centre console (installed from the driver-side of the vehicle).

7. In order to route the cable to the exhaust valve, first take out the driver seat. Next, remove the screws that secure the bottom edge of the driver-side centre console panels. **Refer to Figure 5.**
8. Remove the rear panels behind the seats to open a pathway from the center console to the rear of the vehicle.
9. Starting behind the dash close to the gas pedal, feed the cable under the loose edge of the panel and up into the centre console. Remove the cup holder tray to access the rear section of the console and feed the cable through to the opening at the back. **Refer to Figure 6.** On 4-seat models, the rear cup holder trays should also be removed.
10. Route the cable up (behind the back panel mounts), and out to the exhaust valve. **Refer to Figure 7.**
11. Use the supplied cable ties to secure the cable away from any hot or moving parts. Note that on the 2-seat models there will be extra cable length; coil and tie the extra cable out of the way.

# MBRP



Figure 5

12. Test the exhaust valve for proper operation, then replace the centre console panels, fasteners and seat.

13.  It is recommended to trim the rear fascia above the upper outlet pipe to increase the clearance to at least 1". If clearance is inadequate, the plastic may melt.

14. Install the **14" Foil Tape** and the **10" Foil Tape** to the inside of the rear panel along the centre section nearest to the muffler. Use the **4" Foil Tape** to cover the wire connection (and wire) at the top of the valve.

15. Reinstall the rear panel.



Figure 6



**Caution!** When the exhaust valve is in the closed position there will be increased back pressure – avoid running the engine at or near full-throttle with the valve closed, as this could potentially cause over-heating and/or damage to the vehicle.

**Note:** In order to maintain optimal performance, the spark arrestor screens should be cleaned after the **first 3 hours of use**. Afterwards, clean every 30-35 hours of use.



Figure 7

**Congratulations!** You are ready to begin experiencing the improved performance and driving excitement of your **MBRP** SXS Exhaust upgrade. We know you will enjoy your purchase.