

S6100PLM/SLM

1998.5-2002 Dodge 2500/3500, 5.9L CUMMINS, Turbo-Back, 4.0" Single Side

MBRP

02-APR-24

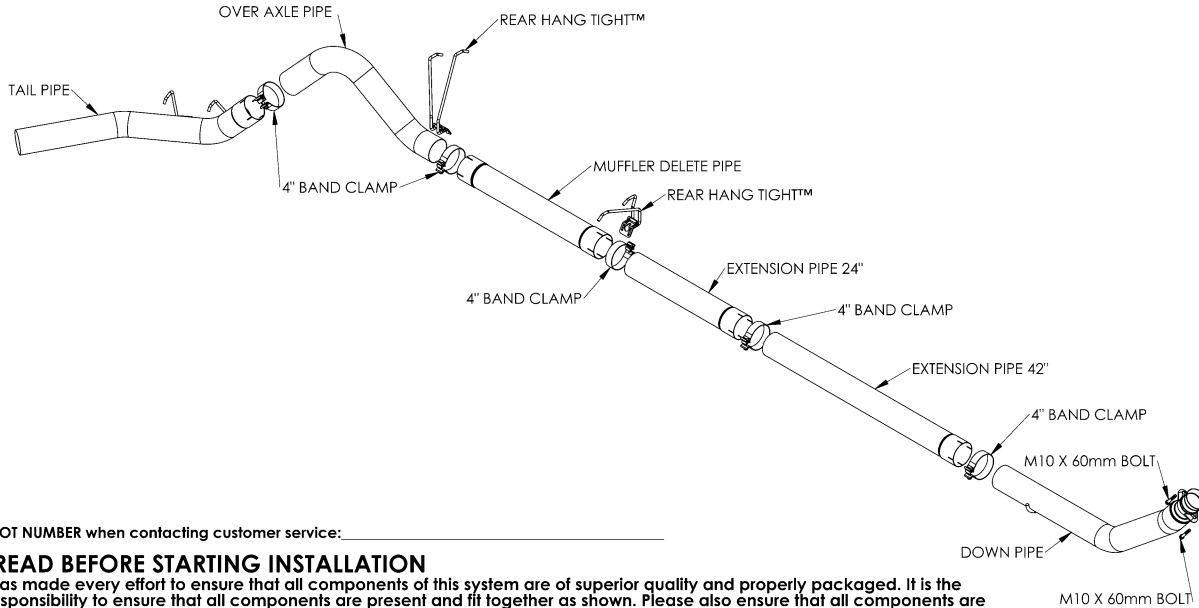

Refer to this LOT NUMBER when contacting customer service: _____

PLEASE READ BEFORE STARTING INSTALLATION

MBRP Inc. has made every effort to ensure that all components of this system are of superior quality and properly packaged. It is the installer's responsibility to ensure that all components are present and fit together as shown. Please also ensure that all components are undamaged before removal of the factory exhaust. Finally, check that this system properly matches the make and model of the vehicle and will not interfere with previous or planned modifications.

Removal of stock system:

1. Separate the stock exhaust system at the slip joint by the muffler. Remove the rear exhaust from rubber hangers and remove the system from under the truck.
2. Using a socket or wrench, remove the two bolts at the turbo flange and remove the stock down pipe.

Installation of MBRP Performance Exhaust:

1. Install the **Down Pipe** in the same position as the stock down pipe placing the hanger into the OEM rubber insulator and attaching the flared end to the turbo using the supplied hardware. Do not fully tighten until all components are in place.
2. Install the **42" Extension Pipe** and **24" Extension Pipe** over the **Down Pipe** using the **4" Band Clamps** provided. The combination of these two **Extension Pipes** provides the required length to fit a Quad Cab Long Bed truck, for Quad Cab Short Bed cut the **42" Extension Pipe** to 26" and for Regular Cab Models cut down to 22".
3. Slide the **Front Hang Tight™** (see **Figure 1** for Hang Tight™ instructions) over the inlet of the **Muffler Delete Pipe**. Then install the **Muffler Delete Pipe** over the **Extension Pipe** and place the **Front Hang Tight™** into the OEM rubber hangers above the inlet.

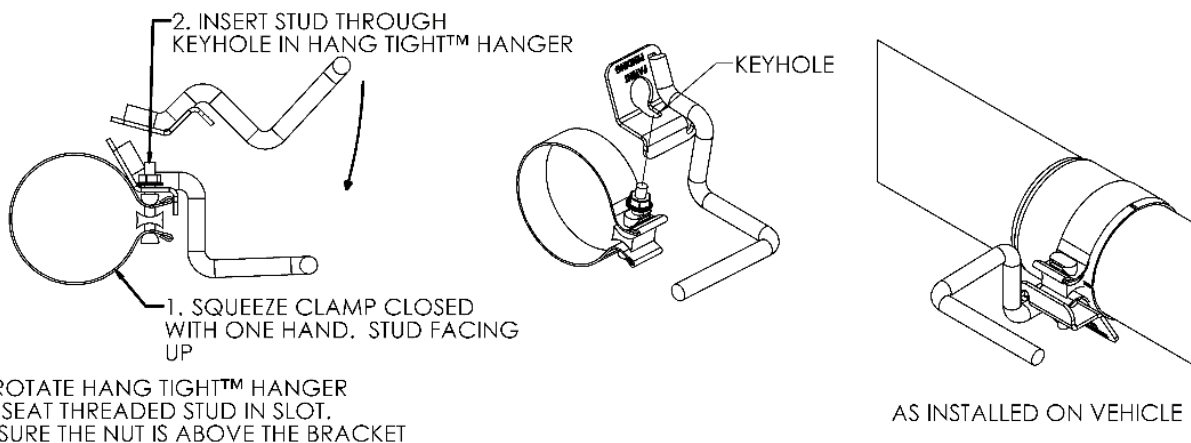

3. ROTATE HANG TIGHT™ HANGER TO SEAT THREADED STUD IN SLOT. BE SURE THE NUT IS ABOVE THE BRACKET

AS INSTALLED ON VEHICLE



Figure 1 (Hanger not as shown)

4. Slide the **Rear Hang Tight™** over the outlet of the **Muffler Delete Pipe** and place the **Rear Hang Tight™** into the OEM rubber hangers above the outlet.
5. Install the **Tail Pipe** and **4" Band Clamp** onto the **Over- Axle Pipe**. From the rear of the truck, Slide the assembly over the axle and attach to the outlet of the **Muffler Delete Pipe**. Install Tail Pipe hangers into the OEM rubber hangers.
6. Install and adjust the **Exhaust Tip** to suit. Tighten the lock bolt located on the **Exhaust Tip**.
7. Tighten all hardware and clamps, starting at the front and working rearward to secure the system. Check along the full length of the exhaust system to ensure there is adequate clearance for fuel lines, vent lines, brake lines, frame, bodywork, suspension, and any wiring, etc. If there is any interference detected, relocate, or adjust to provide adequate clearance. Ensure all clamp connections are secure and components are unable to rotate or slide. Band clamps require approximately 45 lb-ft (60 N-m) of torque. Verify clearances, system security and band clamp torque after 30-60 miles (50-100 km) of driving.

Congratulations! You are ready to begin experiencing the improved performance and driving experience of your MBRP performance exhaust system. We know you will enjoy your purchase.