

AT-9209PT

SINGLE SLIP-ON SYSTEM

2013-2015 CAN-AM OUTLANDER & OUTLANDER MAX
500/650/800/1000 - ALL MODELS
2016-2024 CAN-AM OUTLANDER & OUTLANDER MAX
650/850/1000R - MODELS WITHOUT O2 SENSOR
DOES NOT FIT 6X6 MODELS (REQUIRES TIP W114079)

MBRP

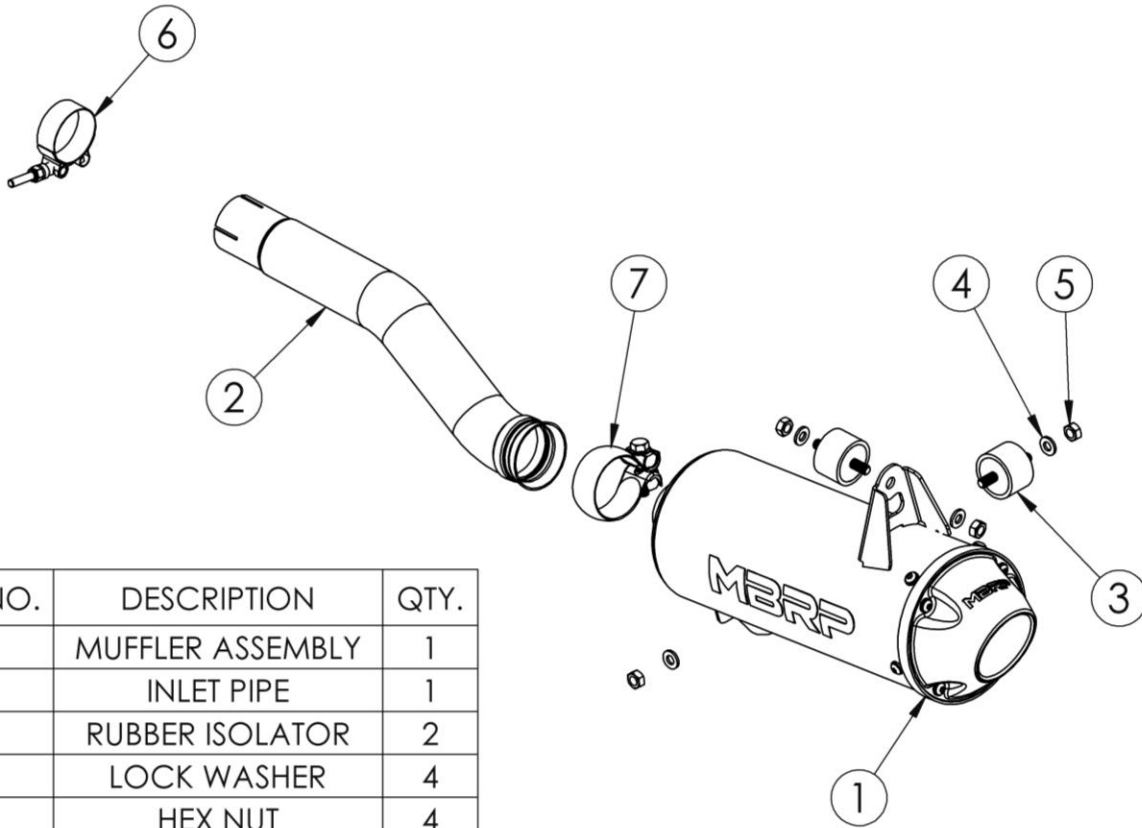

ITEM NO.	DESCRIPTION	QTY.
1	MUFFLER ASSEMBLY	1
2	INLET PIPE	1
3	RUBBER ISOLATOR	2
4	LOCK WASHER	4
5	HEX NUT	4
6	1.875" CLAMP	1
7	INLET CLAMP	1

PLEASE READ BEFORE STARTING INSTALLATION

While MBRP Ltd. has made every effort to ensure that all components of this system are of superior quality and properly packaged, it is the installer's responsibility to ensure the following before removal of the factory exhaust:

- that ALL components shown above are present.
- that ALL mating components fit together.
- that there are no damaged components.
- that the system you have purchased is appropriate for your vehicle year, model and configuration.
- that the system will not interfere with any modifications previously installed or planned.
- that you have read and understand these instructions.

If you have any questions or are uncertain about any aspect of the installation of this system to your vehicle please contact your dealer before commencing installation.

MBRP

Removal of Stock Exhaust:



Figure 1



Figure 2



Figure 3



Figure 4



Figure 5

1. Loosen the clamp at the front pipe of the stock muffler. **Refer to Figure 1.**

2. Loosen and remove the nuts from the upper and lower mounting screws.

Refer to Figures 2 & 3. Note that the door on the rear storage compartment must be open to access the top screw.

3. Remove the mounting screws and then remove the stock muffler by sliding the front pipe off of the exhaust pipe.

Installation of MBRP Exhaust:

1. Place the stock clamp* onto the **Inlet Pipe****, then slide the **Inlet Pipe** onto the stock exhaust pipe. Leave the clamp loose to allow the pipe to be rotated into position as required. Slide the **Inlet Clamp** over the other end of the pipe.

*For model years 2021 and up, use the provided **1.875" Clamp**.

Model years 2017 and below will require using the **Sleeve between the **Inlet Pipe** and the stock clamp.

2. Using a **Lock Washer** and **Hex Nut**, attach one of the **Rubber Isolators** to the top bracket on the **Muffler Assembly**, and the other to the lower mount on the vehicle. **Refer to Figure 4.**

3. Move the **Muffler Assembly** into position by placing the top **Rubber Isolator** into the upper exhaust mounting hole and the bottom muffler bracket onto the lower **Rubber Isolator**. Secure both mounts using the two remaining **Lock Washers** and **Hex Nuts**. **Refer to Figure 4.**

4. Move the **Inlet Pipe** into position to mate to the inlet of the **Muffler Assembly**. Slide the **Inlet Clamp** over the muffler inlet and tighten it until the connection is secure. **Refer to Figure 5.**

5. Finally, verify that exhaust is positioned properly with adequate clearance, and then tighten all connections.

It is recommended that the muffler screws be retightened after the first ride and checked periodically thereafter, tightening if necessary.



Congratulations! You are ready to begin experiencing the improved performance and driving excitement of your MBRP ATV Exhaust upgrade. We know you will enjoy your purchase.



Figure 1



Figure 2



Figure 3



Figure 4

Spark Arrestor Maintenance

In order to maintain optimal performance, the spark arrestor screen should be cleaned after the first 3 hours of use. Afterwards, clean every 30-35 hours of use.

Clean-out Instructions:

Make sure the vehicle is cool before completing the clean-out procedure.

1. Using a 4mm hex key, remove the 4 screws securing the outlet cap or tip. **(Figure 1)**
2. Remove the outlet cap to expose the spark arrestor screen insert. **(Figure 2)**
3. Remove the screen insert. **(Figure 3)**
4. Using a wire brush, thoroughly brush the screen to remove residue. **(Figure 4)**
5. Replace the screen and cap.
6. Tighten the screws to 60 in-lbs (6.8 Nm).