

AT-9110SP

SPORT MUFFLER ASSEMBLY
2019-UP, HONDA TALON, 1000

MBRP

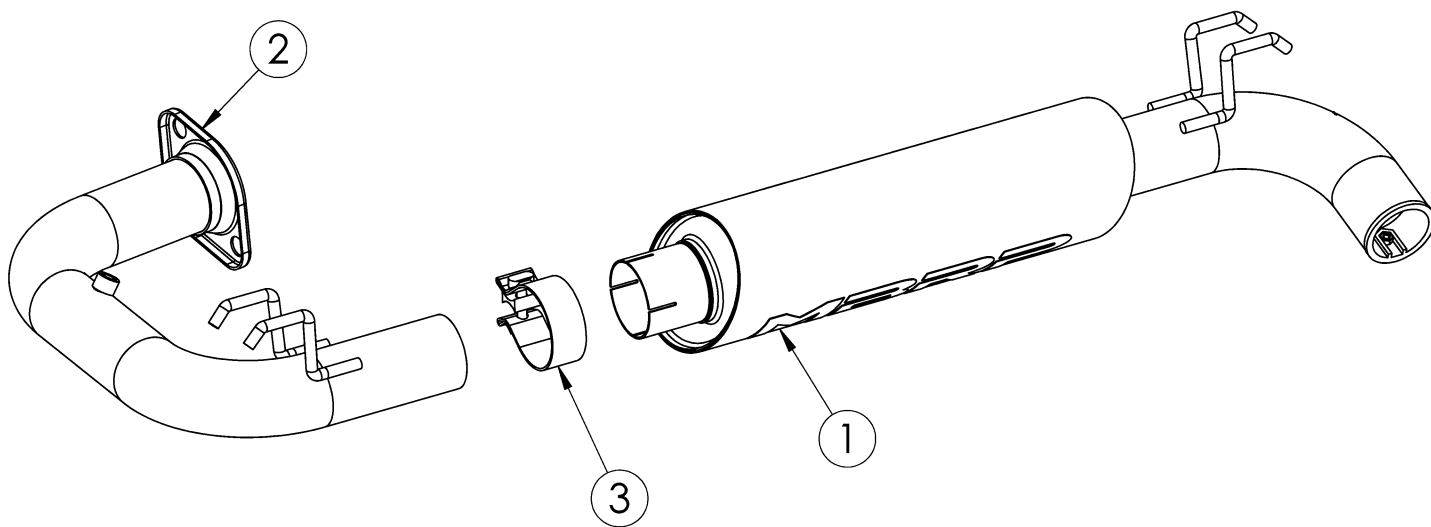

ITEM NO.	DESCRIPTION	QTY.
1	MUFFLER ASSEMBLY	1
2	INLET PIPE	1
3	2.5" CLAMP	1

PLEASE READ BEFORE STARTING INSTALLATION

While MBRP Ltd. has made every effort to ensure that all components of this system are of superior quality and properly packaged, it is the installer's responsibility to ensure the following before removal of the factory exhaust:

- that ALL components shown above are present.
- that ALL mating components fit together.
- that there are no damaged components.
- that the system you have purchased is appropriate for your vehicle year, model and configuration.
- that the system will not interfere with any modifications previously installed or planned.
- that you have read and understand these instructions.

If you have any questions or are uncertain about any aspect of the installation of this system to your vehicle please contact your dealer before commencing installation.

MBRP

Removal of Stock Exhaust:

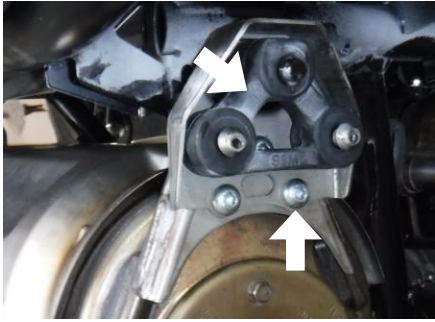

Figure 1



Figure 2



Figure 3



Figure 4



Figure 5

1. Remove the sensor from the muffler inlet pipe.
2. Remove the rubber isolator from the hangers on the outlet end of the muffler, then remove the limiter bracket by removing the three (3) screws. Keep the isolator as it will be reused. **Refer to Figure 1**
3. Loosen and remove the bolts (2) and springs (2) securing the muffler inlet flange to the front pipe. Keep the hardware as it will be reused. **Refer to Figure 2**
4. Remove the rubber isolator (do not discard) from the inlet side of the Muffler, then remove the muffler.

Installation of MBRP Exhaust:

1. Install one of the rubber isolators onto the hangers of the **Inlet Pipe**, then install the isolator onto the vehicle hanger. Put the **Inlet Pipe** flange in place onto the front pipe, (ensure the stock gasket is on the end of the front pipe) and secure it by loosely installing the bolts (2) and springs (2). **Refer to Figure 3.**
2. Install the other rubber isolator onto the hangers of the **Muffler Assembly** and slide the **Clamp** onto the muffler inlet.
3. Put the **Muffler Assembly** in place by sliding the inlet over the **Front Pipe** and installing the rubber isolator onto the vehicle hanger. **Refer to Figure 4.**
4. Centre the **Muffler Assembly**, and then fully tighten the **Clamp** and flange hardware on the **Inlet Pipe**. **Refer to Figure 4**
5. Reinstall the sensor into the port on the **Inlet Pipe**.

Note: In order to maintain optimal performance, the spark arrestor screen should be cleaned after the **first 3 hours of use**. Afterwards, clean every 30-35 hours of use.



Congratulations! You are ready to begin experiencing the improved performance and driving excitement of your MBRP Exhaust upgrade. We know you will enjoy your purchase.