

AT-9406PT

2016-UP YAMAHA YXZ 1000R, SLIP-ON

MBRP®

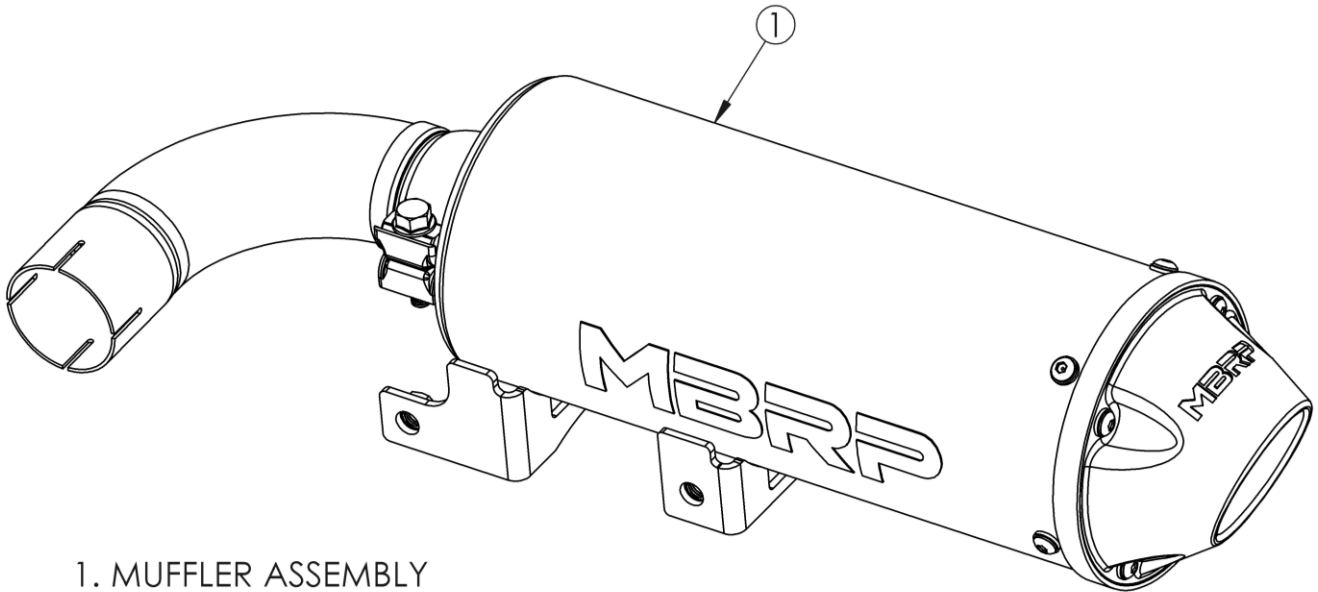

1. MUFFLER ASSEMBLY

Refer to this LOT NUMBER when contacting customer service: _____

PLEASE READ BEFORE STARTING INSTALLATION

While MBRP has made every effort to ensure that all components of this system are of superior quality and properly packaged, it is the installer's responsibility to ensure the following before removal of the factory exhaust:

- that ALL components shown above are present.
- that ALL mating components fit together.
- that there are no damaged components.
- that the system you have purchased is appropriate for your vehicle year, model and configuration.
- that the system will not interfere with any modifications previously installed or planned.
- that you have read and understand these instructions.

If you have any questions or are uncertain about any aspect of the installation of this system to your vehicle please contact your dealer before commencing installation.

Removal of Stock Exhaust:

1. Remove the 6 nuts securing the header to the cylinder head and loosen the clamp connecting the header to the muffler. Keep all hardware as it is needed for installation. **Refer to Figure 1.**
2. Remove the four bolts securing the muffler to the frame. **Refer to Figure 2.**
3. Remove the two bolts securing the rear muffler bracket and move bracket out of the way of the muffler. **Refer to Figure 3.**
4. Rotate the muffler while pulling it out to the rear of the vehicle.

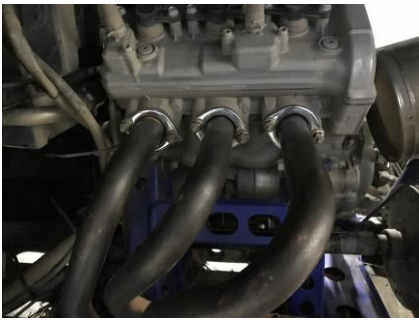

Figure 1



Figure 2



Figure 3



Figure 4



Figure 5

Installation of MBRP Powersports Exhaust:

1. Re-install the rear muffler bracket that was removed previously in removal step 3. **Refer to Figure 3.**
2. Rotate the **Muffler Assembly** while guiding it in from the rear of the vehicle and install it using the previously removed hardware from step 2. **Refer to Figure 4.**
3. Re-install the stock header using the previously removed hardware and clamp. **Refer to Figure 5.**

Note:

It is recommended that the muffler screws be retightened after the first ride and checked periodically thereafter, tightening if necessary.



Congratulations! You are ready to begin experiencing the improved performance and driving excitement of your MBRP Powersports ATV Exhaust upgrade. We know you will enjoy your purchase.



Figure 1



Figure 2



Figure 3



Figure 4

Spark Arrester Maintenance

In order to maintain optimal performance, the spark arrester screen should be cleaned after the first 3 hours of use. Afterwards, clean every 30-35 hours of use.

Clean-out Instructions:

Make sure the vehicle is cool before completing the clean-out procedure.

1. Using a 4mm hex key, remove the 4 screws securing the outlet cap or tip. **(Figure 1)**
2. Remove the outlet cap to expose the spark arrester screen insert. **(Figure 2)**
3. Remove the screen insert. **(Figure 3)**
4. Using a wire brush, thoroughly brush the screen to remove residue. **(Figure 4)**
5. Replace the screen and cap.
6. Tighten the screws to 60 in-lbs (6.8 Nm).