

## 229IC

INTERCOOLER PIPES  
2012-2016 ARCTIC CAT Z1 TURBO  
ProClimb / ProCross 1100 Turbo

# MBRP

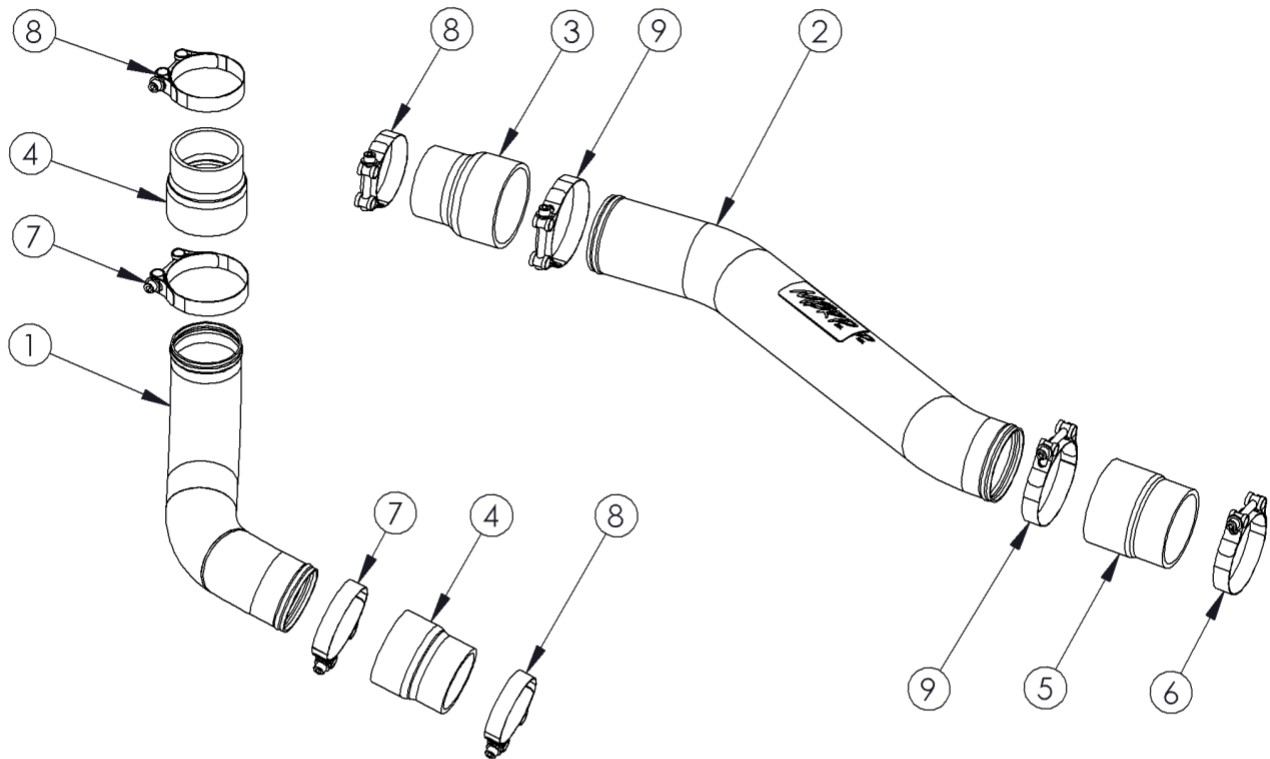

1. INTERCOOLER INLET PIPE
2. INTERCOOLER OUTLET PIPE
3. 2.5" TO 2" HOSE COUPLER
4. 2.25" TO 2" HOSE COUPLER (2 PCS)
5. 2.5" TO 2.35" HOSE COUPLER
6. 2.375" BARREL CLAMP (3 PCS)
7. 2.625" BARREL CLAMP (2 PCS)
8. 2.75" BARREL CLAMP
9. 2.875" BARREL CLAMP (2 PCS)

### PLEASE READ BEFORE STARTING INSTALLATION

While MBRP Inc. has made every effort to ensure that all components of this product are of superior quality and properly packaged it is the installer's responsibility to ensure the following before removal of the factory components:

- that ALL components shown above are present.
- that ALL mating components fit together.
- that there are no damaged components.
- that the product you have purchased is appropriate for your vehicle year, model and configuration.
- that the product will not interfere with any modifications previously installed or planned.
- that you have read and understand these instructions.

If you have any questions or are uncertain about any aspect of the installation of this product to your vehicle please contact your dealer before commencing installation.

# MBRP

229IC - Fits 2012-2016 Arctic Cat 1100 Pro Cross / Pro Climb Turbo

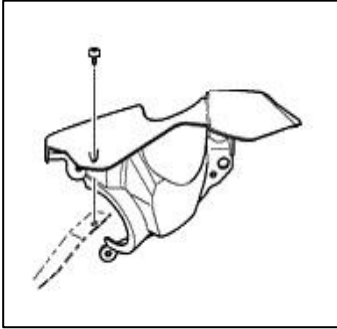

Figure 1

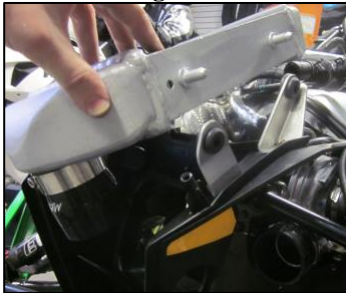

Figure 2



Figure 3



Figure 4



Figure 5

## Removal of Stock Intercooler Hoses:

1. Remove the engine cover.
2. Remove the plastic fascia covering the turbo outlet. Refer to Figure 1.
3. Loosen the band clamps and remove the hoses from the intercooler, turbo, and intake.

## Installation of MBRP Inc. Intercooler Pipes:

1. Place the **2.5" to 2.35" Hose Coupler** onto the snowmobile intake and secure it using a **2.75" Barrel Clamp**. Insert the **Intercooler Outlet Pipe** into the hose coupler. Place a **2.875" Barrel Clamp** over the hose, but do not tighten it yet.
2. Remove the four (4) screws securing the front bumper and then remove the bumper.
3. Place a **2.25" to 2" Hose Coupler** onto the turbo outlet and secure it using a **2.375" Barrel Clamp**.
4. Place the other **2.25" to 2" Hose Coupler** onto the intercooler inlet and secure it using a **2.375" Barrel Clamp**.
5. In order to attach both pipes to the intercooler, it is helpful to detach the left side of the intercooler by removing the small hoses and extracting the mounting posts from the rubber mounting holes. **Refer to Figure 2.**
6. Place the **2.5" to 2" Hose Coupler** onto the intercooler outlet and secure it with a **2.375" Barrel Clamp**.
8. Insert the **Intercooler Outlet Pipe** into the **2.5" to 2" Hose Coupler** attached to the intercooler outlet, placing a **2.875" Barrel Clamp** over the hose coupler. Do not tighten the barrel clamp yet.
9. If reinstalling the front bumper, it will be necessary to trim the lower portion of the top-left bumper attachment (closest to the turbo outlet) to allow clearance for the **Intercooler Inlet Pipe**. **Refer to Figure 3.**
10. Hold the bumper in place (but unattached) and then install the **Intercooler Inlet Pipe** through the intake plenum hole and into the hose couplers attached to the turbo and intercooler (place a **2.625" Barrel Clamp** over each hose). It will be necessary to hold the bumper up above its normal position in order to insert the pipe into the hose on the turbo outlet.
11. Reinsert the intercooler mounting posts to correctly position the intercooler. If there is not adequate clearance between the pipe and the bumper, or the pipe and the intake plenum, remove the pipe and trim away more of the bumper or enlarge the intake plenum hole. **Refer to Figure 4.**
12. When the **Intercooler Inlet Pipe** is in position with adequate clearance, reinstall the bumper using the bolts removed in **Step 2**. **Refer to Figure 5.**
13. Adjust the **Intercooler Pipes** as needed for optimal fit and clearance, and then tighten all of the **Barrel Clamps**.
14. Reattach the small hoses at the top end of the intercooler.
15. Reinstall the plastic fascia over the turbo outlet. **Trim the fascia as necessary for clearance around the barrel clamp on the turbo outlet.**
16. Replace the engine cover.

**Congratulations!** You are ready to begin experiencing the improved performance and driving excitement of your MBRP Inc. intercooler pipe upgrade. We know you will enjoy your purchase.