

AT-9519PT

SLIP-ON DUAL EXHAUST ASSEMBLY
2016-UP POLARIS RZR S 1000
2016-UP POLARIS GENERAL 1000

MBRP®

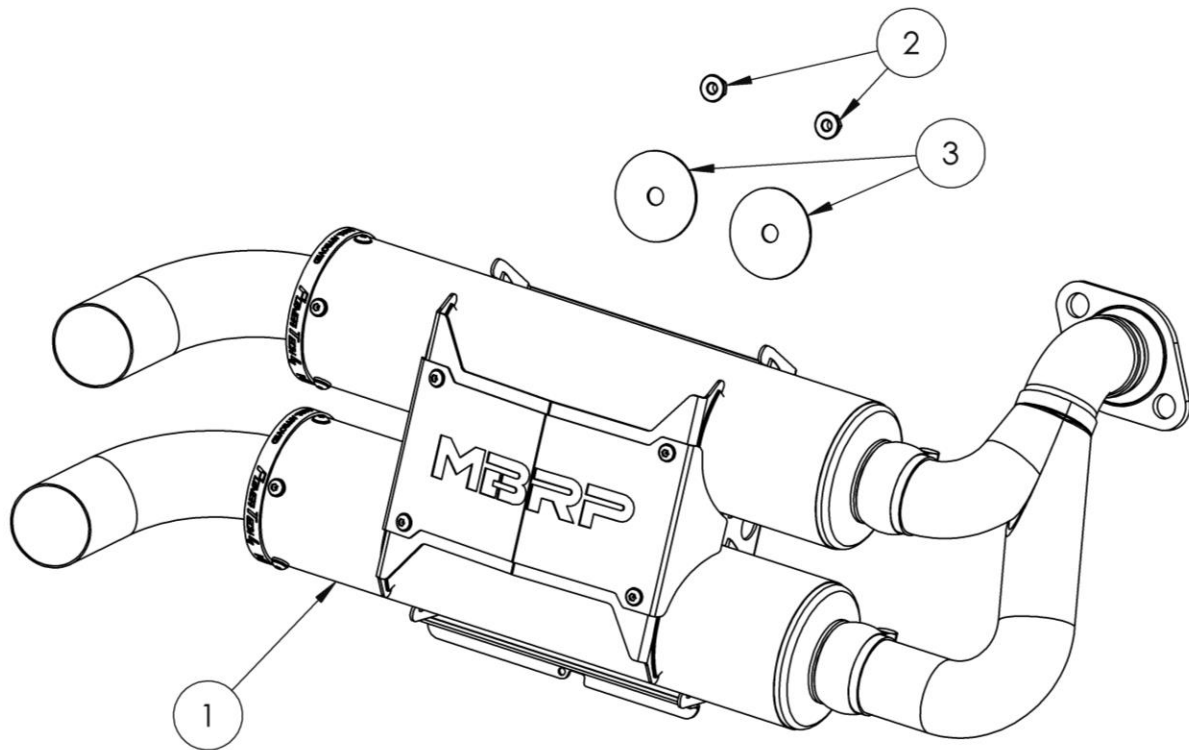

1. MUFFLER ASSEMBLY
2. FLANGE NUT (2 PCS)
3. FENDER WASHER (2 PCS)

PLEASE READ BEFORE STARTING INSTALLATION

While MBRP Ltd. has made every effort to ensure that all components of this system are of superior quality and properly packaged, it is the installer's responsibility to ensure the following before removal of the factory exhaust:

- that ALL components shown above are present.
- that ALL mating components fit together.
- that there are no damaged components.
- that the system you have purchased is appropriate for your vehicle year, model and configuration.
- that the system will not interfere with any modifications previously installed or planned.
- that you have read and understand these instructions.

If you have any questions or are uncertain about any aspect of the installation of this system to your vehicle please contact your dealer before commencing installation.

Removal of Stock Exhaust:

1. Remove the upper and lower springs securing the muffler to the vehicle. Do not discard the springs. Only the lower spring is re-used.

Refer to Figure 1.

2. Remove the 2 bolts and springs securing the muffler inlet to the exhaust pipe. Do not discard them. Leave the gasket on the vehicle exhaust pipe.

Refer to Figure 1.

3. Remove the muffler by sliding the hangers out of the rubber isolators.



Figure 1

Installation of MBRP Exhaust:

1. Note the position of the holes in the vehicle frame used to mount the rubber isolators on the **MBRP Muffler Assembly**.

Refer to Figure 2.

2. Slide the hanger rods into the rubber isolators on the vehicle and mate the **Muffler Assembly** inlet pipe to the end of the exhaust pipe.

*If necessary, the position of the muffler support bracket can be adjusted by removing the logo plate and loosening the two (2) 8mm bolts holding the brackets together.

3. Secure the inlet using the previously removed stock bolts and springs.

*If necessary, the inlet y-pipe can be adjusted by loosening the muffler inlet clamps.

Refer to Figure 4.

4. Secure the **Muffler Assembly** by attaching the previously removed spring at the lower location, using the mounting hole in the support bracket.

Refer to Figure 3.

5. Install the **Fender Washers** and **Flange Nuts** onto the rubber isolators where they pass through the vehicle frame.

Refer to Figure 5.

6. Ensure there is adequate clearance between the exhaust system and other parts of the vehicle or accessories. Carefully check with the box in the dump position and the tailgate lowered. The mufflers can be rotated as explained in steps 2 and 3 if necessary.

It is recommended that the muffler screws be retightened after the first ride and checked periodically thereafter, tightening if necessary.

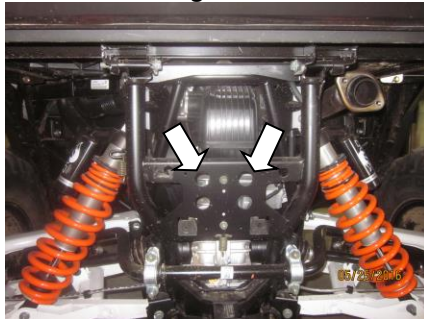

Figure 2



Figure 3



Figure 4



Figure 5



Congratulations! You are ready to begin experiencing the improved performance and driving excitement of your **MBRP** ATV Exhaust upgrade. We know you will enjoy your purchase.



Figure 1



Figure 2



Figure 3



Figure 4

Spark Arrestor Maintenance

In order to maintain optimal performance, the spark arrestor screen should be cleaned after the first 3 hours of use. Afterwards, clean every 30-35 hours of use.

Clean-out Instructions:

Make sure the vehicle is cool before completing the clean-out procedure.

1. Using a 4mm hex key, remove the 4 screws securing the outlet cap or tip. **(Figure 1)**
2. Remove the outlet cap to expose the spark arrestor screen insert. **(Figure 2)**
3. Remove the screen insert. **(Figure 3)**
4. Using a wire brush, thoroughly brush the screen to remove residue. **(Figure 4)**
5. Replace the screen and cap.
6. Tighten the screws to 60 in-lbs (6.8 Nm).