

# AT-9515PT

SLIP-ON EXHAUST ASSEMBLY  
2011-2013 POLARIS RZR XP 900  
2014 POLARIS RZR 900

# MBRP®

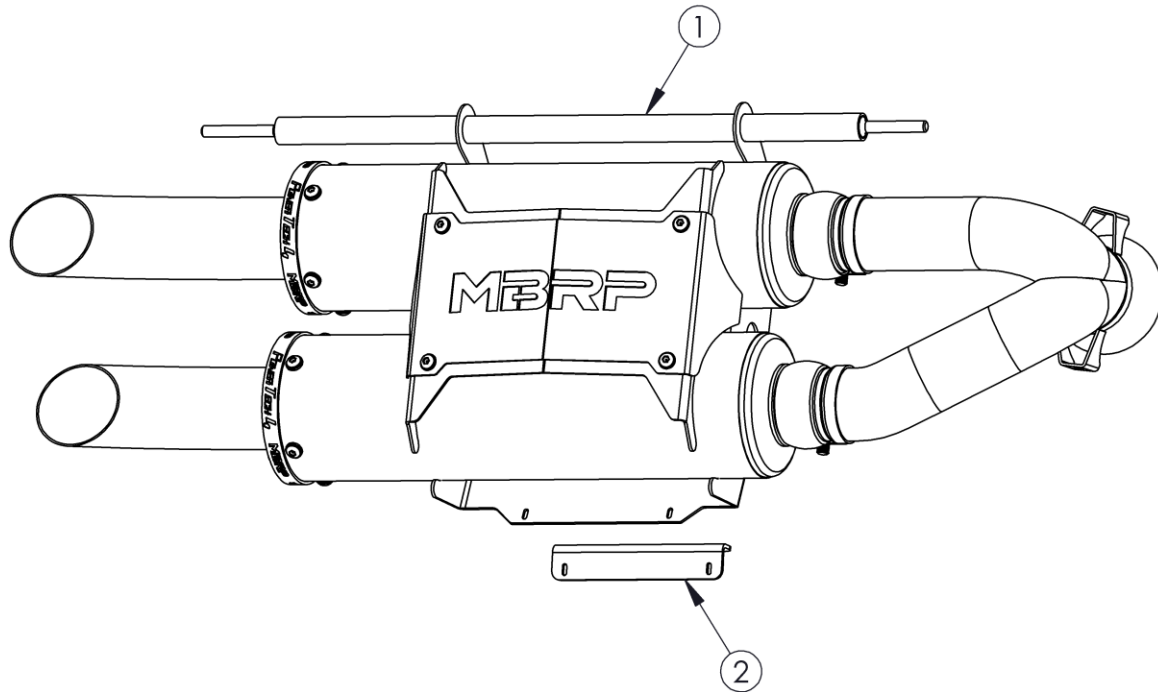

1. MUFFLER ASSEMBLY
2. SPRING BRACKET

## PLEASE READ BEFORE STARTING INSTALLATION

While MBRP Ltd. has made every effort to ensure that all components of this system are of superior quality and properly packaged, it is the installer's responsibility to ensure the following before removal of the factory exhaust:

- that ALL components shown above are present.
- that ALL mating components fit together.
- that there are no damaged components.
- that the system you have purchased is appropriate for your vehicle year, model and configuration.
- that the system will not interfere with any modifications previously installed or planned.
- that you have read and understand these instructions.

If you have any questions or are uncertain about any aspect of the installation of this system to your vehicle please contact your dealer before commencing installation.

# MBRP®

## Removal of Stock Exhaust:



Figure 1

1. Remove the springs securing the muffler inlet to the exhaust pipe. Do not discard the springs.
2. Remove the springs attached to the support bracket on the bottom of the muffler. Do not discard the springs.
3. Remove the muffler (and heat shield) by sliding the hangers out of the rubber isolators.

## Installation of MBRP Exhaust:

1. Remove the two nuts on the downward-facing surface of the rear frame (above the rear brace plate) and install the **Spring Bracket** over the stock bolts, and then re-install the nuts. **Refer to Figure 1.**
2. Slide the ends of the **Muffler support rod** into the rubber isolators on the vehicle, starting with the left-hand side isolator then the right-hand side.
3. Position the **Muffler** Assembly such that the muffler inlet pipe is aligned with the exhaust pipe.  
\*If necessary, the position of the muffler support brackets can be adjusted by removing the logo plate (be careful not to lose the 6mm lock washers behind the plate) and loosening the two (2) 8mm bolts holding the brackets together.
4. Secure the **Muffler** inlet using the springs previously removed.
5. Finally, re-install the two springs at the bottom of the muffler assembly onto the **Spring Bracket** installed in Step 1.

It is recommended that the muffler screws be retightened after the first ride and checked periodically thereafter, tightening if necessary.



**Congratulations!** You are ready to begin experiencing the improved performance and driving excitement of your MBRP ATV Exhaust upgrade. We know you will enjoy your purchase.



**Figure 1**



**Figure 2**



**Figure 3**



**Figure 4**

## Spark Arrestor Maintenance

In order to maintain optimal performance, the spark arrestor screen should be cleaned after the first 3 hours of use. Afterwards, clean every 30-35 hours of use.

## Clean-out Instructions:

Make sure the vehicle is cool before completing the clean-out procedure.

1. Using a 4mm hex key, remove the 4 screws securing the outlet cap or tip. **(Figure 1)**
2. Remove the outlet cap to expose the spark arrestor screen insert. **(Figure 2)**
3. Remove the screen insert. **(Figure 3)**
4. Using a wire brush, thoroughly brush the screen to remove residue. **(Figure 4)**
5. Replace the screen and cap.
6. Tighten the screws to 60 in-lbs (6.8 Nm).