

AT-9522SP

SLIP-ON SPORT EXHAUST ASSEMBLY
2018-2023 POLARIS RZR XP 1000
2018-2022 POLARIS RZR RS1

MBRP®

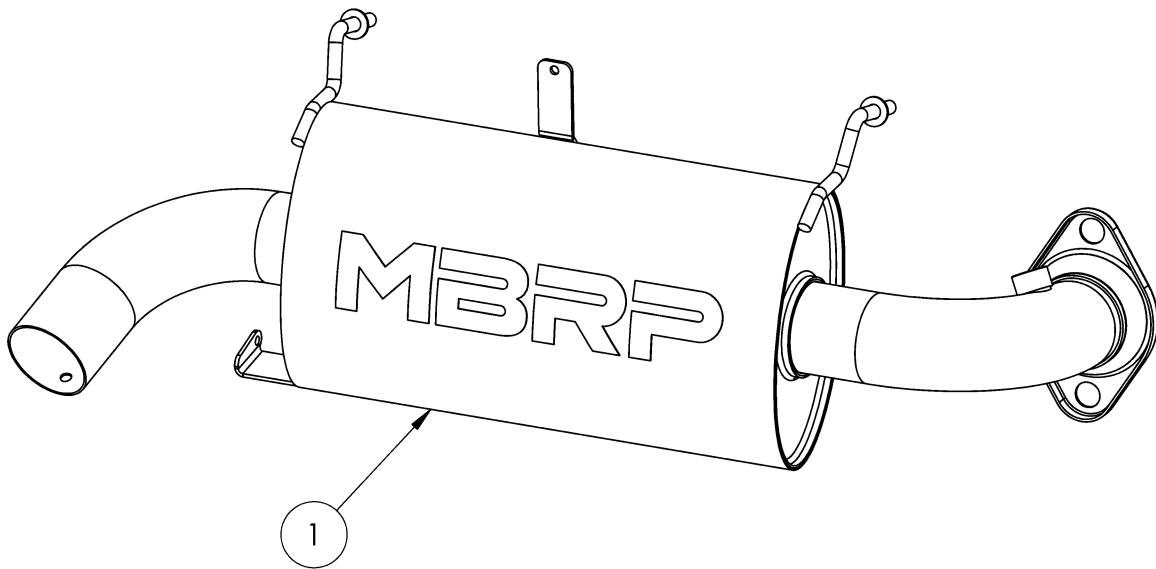

1. MUFFLER ASSEMBLY

PLEASE READ BEFORE STARTING INSTALLATION

While MBRP Inc. has made every effort to ensure that all components of this system are of superior quality and properly packaged, it is the installer's responsibility to ensure the following before removal of the factory exhaust:

- that ALL components shown above are present.
- that ALL mating components fit together.
- that there are no damaged components.
- that the system you have purchased is appropriate for your vehicle year, model and configuration.
- that the system will not interfere with any modifications previously installed or planned.
- that you have read and understand these instructions.

If you have any questions or are uncertain about any aspect of the installation of this system to your vehicle please contact your dealer before commencing installation.

MBRP®

Removal of Stock Exhaust:

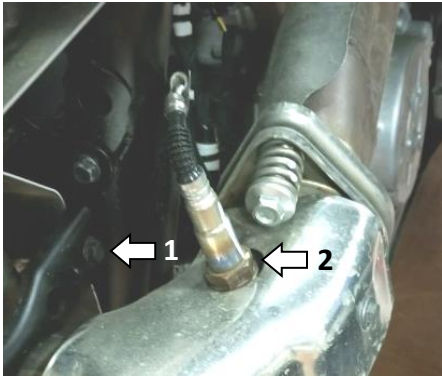

Figure 1

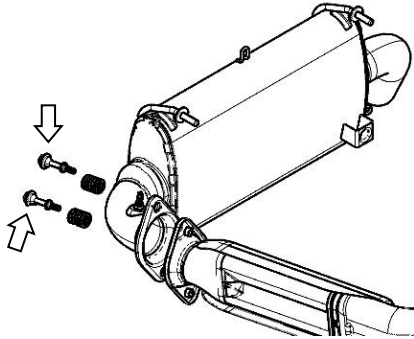

Figure 2



Figure 3



Figure 4



Figure 5

1. Remove the muffer cover by removing the four (4) screws securing the cover brackets to the vehicle. **Refer to Figure 1.**

2. Remove the O2 sensor from the muffer inlet pipe. It will be reused. **Refer to Figure 1.**

3. Remove bolts and springs securing the muffer inlet to the exhaust pipe. Do not discard them. **Refer to Figure 2.**

4. Remove the upper and lower springs securing the muffer to the vehicle. Do not discard the springs. **Refer to Figure 3.**

5. Remove the muffer by sliding the hangers out of the rubber isolators.

Installation of MBRP Powersports Exhaust:

1. Slide the hanger rods into the rubber isolators on the vehicle and mate the **Muffer Assembly** inlet pipe to the end of the exhaust pipe. **Refer to Figure 4.**

2. Secure the **Muffer Assembly** by first attaching the previously removed spring at the top location, using the mounting hole in the support bracket.

3. Ensure the lower mount is behind the heat shield and over the round boss on the vehicle body and secure it with the stock spring.

4. Secure the inlet using the previously removed stock bolts and springs. **Refer to Figure 5**

5. Finally, replace the O2 sensor in the provided bung on the inlet pipe.

It is recommended that the muffer screws be retightened after the first ride and checked periodically thereafter, tightening if necessary.

Note: To maintain optimal performance, the spark arrestor screen should be cleaned after the **first 3 hours of use**. Afterwards, clean every 30-35 hours of use.



Congratulations! You are ready to begin experiencing the improved performance and driving excitement of your MBRP Powersports SXS Exhaust upgrade. We know you will enjoy your purchase.