

AT-9533PT

MUFFLER ASSEMBLY, PERFORMANCE
2022-UP POLARIS RZR PRO R

MBRP

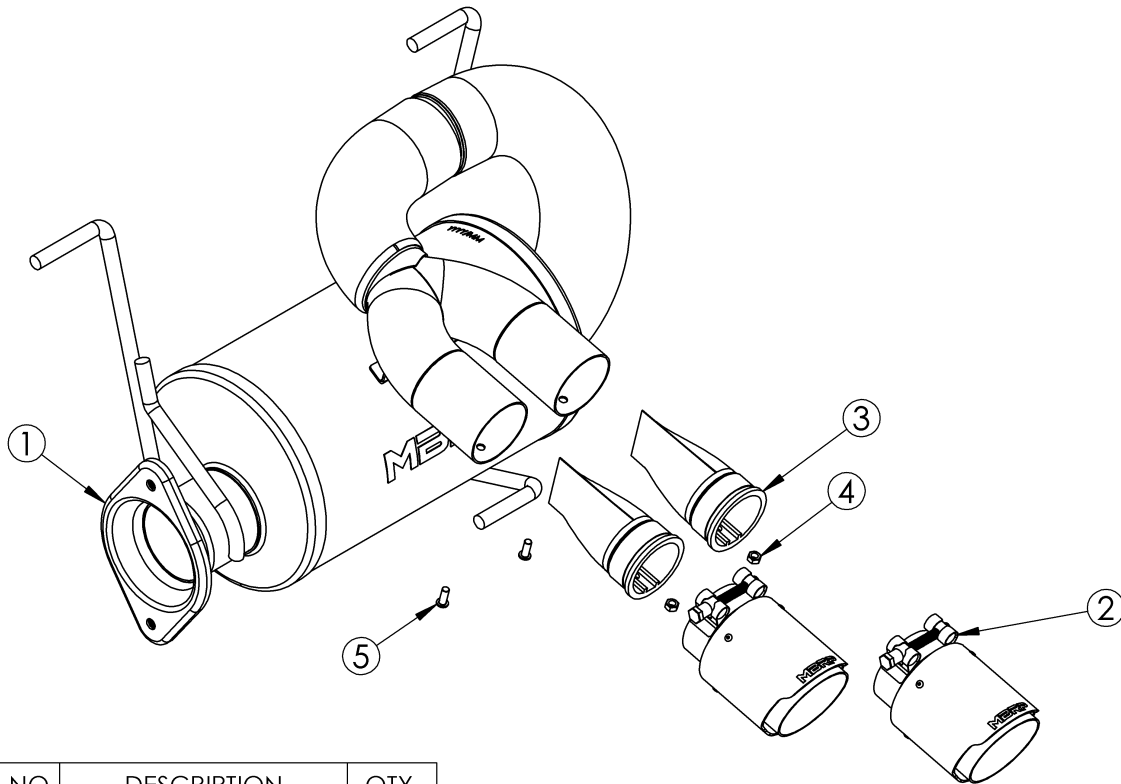

ITEM NO.	DESCRIPTION	QTY.
1	MUFFLER ASSEMBLY	1
2	TIP	2
3	SPARK ARRESTOR	2
4	NUT	2
5	SCREW	2

ITEMS 3, 4 & 5 ARE PRE-ASSEMBLED TO MUFFLER

PLEASE READ BEFORE STARTING INSTALLATION

While MBRP Ltd. has made every effort to ensure that all components of this system are of superior quality and properly packaged, it is the installer's responsibility to ensure the following before removal of the factory exhaust:

- that ALL components shown above are present.
- that ALL mating components fit together.
- that there are no damaged components.
- that the system you have purchased is appropriate for your vehicle year, model and configuration.
- that the system will not interfere with any modifications previously installed or planned.
- that you have read and understand these instructions.

If you have any questions or are uncertain about any aspect of the installation of this system to your vehicle please contact your dealer before commencing installation.

MBRP

Removal of Stock Exhaust:



Figure 1



Figure 2



Figure 3

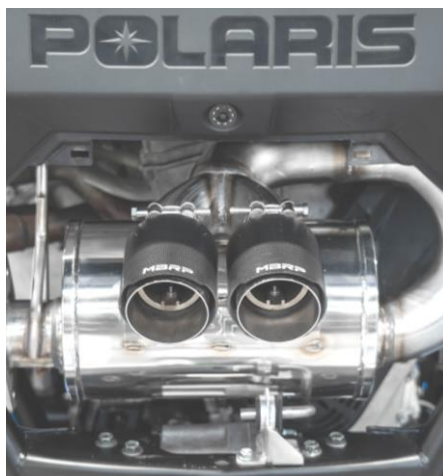

Figure 4

1. Apply penetrating lubricant liberally to all exhaust fasteners, hangers, and rubber isolators.
2. Remove the center rear fascia panel that surrounds the exhaust tip (remove the two (2) screws and pull the panel to unclip it from the main rear fascia). **Refer to Figure 1.**
**If equipped, remove the rear bumper to access to the center panel.*
3. Loosen and remove the two (2) bolts (and springs) securing the muffer inlet flange to the header pipe flange. Keep the hardware as it will be reused to mount the new system. **Refer to Figure 2.**
4. Loosen and remove the screws (2) securing the bottom hanger mount to the frame. Slide the mount (isolator and bracket) off of the exhaust hanger and set it aside to be reused with the new exhaust. **Refer to Figure 3.**
5. Carefully slide the stock muffer towards the passenger side to free the upper hangers from the mounts. Leave the stock gasket in place on the header pipe.
6. With the muffer free, remove it through the center opening of the frame.

Installation of MBRP Exhaust:

1. Place the **Muffer Assembly** into position through the rear frame opening, and then slide the top hangers into the isolator mounts. When sliding the **Muffer Assembly** in place, carefully line up the inlet flange with the stock gasket to avoid damaging the gasket.
2. Slide the bottom mount onto the lower exhaust hanger, and once aligned, reinstall the screws (2) to secure it to the frame.
3. Reinstall the two (2) bolts and springs to secure the muffer inlet flange to the header pipe flange.
4. In order to install the **Tips**, the **Screw** securing each **Spark Arrestor** must be removed temporarily. Be careful not to lose the **Nuts** on the inside of the **Spark Arrestors**, as they may fall out when the **Screw** is removed.
5. With the **Screw** removed, slide the **Tip** (with clamp) over the **Muffer** outlet and line up the hole in the bottom of the **Tip** with the screw hole in the **Muffer** outlet. Holding the **Nut** and **Spark Arrestor** in place (re-align the **Nut** with the hole if necessary), reinstall the **Screw** through the hole in the **Tip**. Repeat for the other side, then position the **Tips** and tighten each clamp to secure them. **Refer to Figure 4.**
6. Finally, replace the center rear fascia panel.

It is recommended that the hardware be retightened after the first ride and checked periodically thereafter, tightening if necessary. In order to maintain optimal performance, the spark arrestor screen should be cleaned after every 30-35 hours of use.

Congratulations! You are ready to begin experiencing the improved performance and driving excitement of your **MBRP** Ltd. Exhaust upgrade. We know you will enjoy your purchase.