

AT-9301PT

PERFORMANCE MUFFLER, SLIP-ON
2020 & UP KAWASAKI TERYX KRX 1000

MBRP

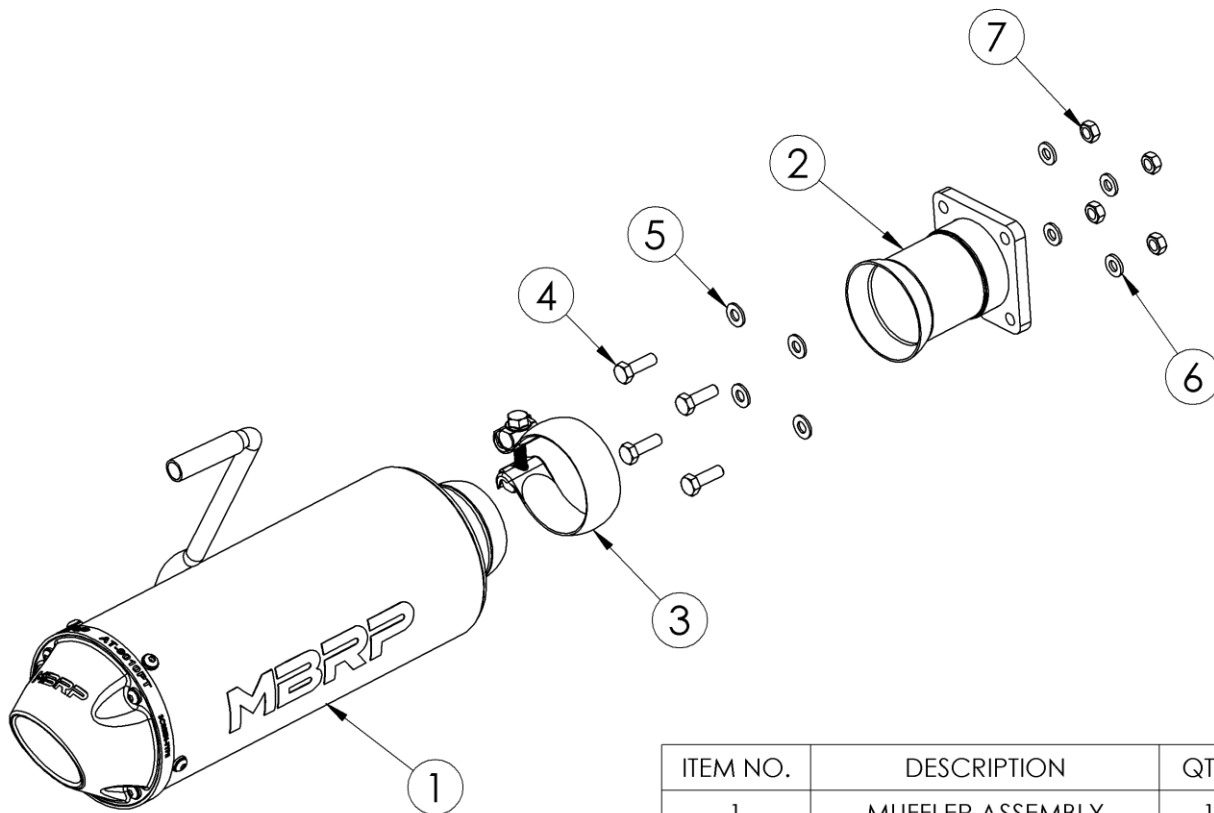

| ITEM NO. | DESCRIPTION | QTY. |
|----------|------------------|------|
| 1 | MUFFLER ASSEMBLY | 1 |
| 2 | INLET PIPE | 1 |
| 3 | INLET CLAMP | 1 |
| 4 | HEX BOLT (M8X25) | 4 |
| 5 | FLAT WASHER | 4 |
| 6 | LOCK WASHER | 4 |
| 7 | NUT | 4 |

PLEASE READ BEFORE STARTING INSTALLATION

While MBRP Ltd. has made every effort to ensure that all components of this system are of superior quality and properly packaged, it is the installer's responsibility to ensure the following before removal of the factory exhaust:

- that ALL components shown above are present.
- that ALL mating components fit together.
- that there are no damaged components.
- that the system you have purchased is appropriate for your vehicle year, model and configuration.
- that the system will not interfere with any modifications previously installed or planned.
- that you have read and understand these instructions.

If you have any questions or are uncertain about any aspect of the installation of this system to your vehicle please contact your dealer before commencing installation.

MBRP

Removal of Stock Exhaust:



Figure 1

1. Remove the four (4) nuts from the outlet flange of the stock front pipe. Retain the nuts as they will be reused. **Refer to Figure 1**

2. Remove the two (2) bolts securing the lower isolator mount to the vehicle frame. **Refer to Figure 2**



Figure 2

3. Remove the single bolt holding the front inner isolator mount to the vehicle. **Refer to Figure 3**

4. Finally, while supporting the stock muffler, remove the two (2) bolts securing the upper rear isolator mount (**Refer to Figure 4**), then remove the muffler. Retain the isolator mount and bolts as they will be reused.

Installation of MBRP Exhaust:



Figure 3

1. Reinstall the upper rear isolator mount, but leave the bolts loose enough that the bracket can move slightly. **Refer to Figure 4.**

2. Make sure that the stock circular gasket is in place at the outlet of the front pipe. If it came off with the muffler, put it back in place.

3. Using the provided **Hex Bolts, Nuts, and Washers**, install the **Inlet Pipe** onto the front pipe flange with the notch of the **Inlet Pipe** flange at the bottom.

4. Loosen the **Clamp** and place it over the inlet of the **Muffler Assembly**.

5. Move the **Muffler Assembly** into position by placing the top hanger into the upper isolator mount and then aligning the muffler inlet to the front pipe. Slide the clamp over the inlet pipe and tighten it to secure the muffler. **Refer to Figure 5.**



Figure 4

6. Slide the lower isolator mount over the lower hanger on the **Muffler Assembly**, then loosely reinstall it to the frame using the bolts that were removed previously.

7. Finally, verify that exhaust is positioned properly with adequate clearance, and then fully tighten all connections.

*It is recommended that the muffler screws be retightened after the first ride and checked periodically thereafter, tightening if necessary.

Note: In order to maintain optimal performance, the spark arrestor screen should be cleaned after every 30-35 hours of use.

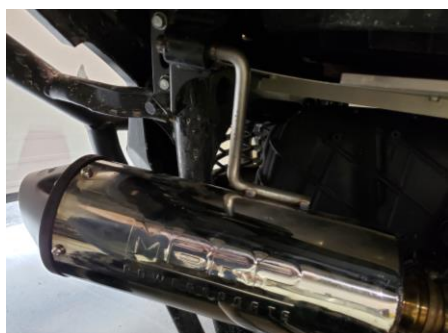

Figure 5

Congratulations! You are ready to begin experiencing the improved performance and driving excitement of your **MBRP** Exhaust upgrade. We know you will enjoy your purchase.

MBRP

Spark Arrestor Maintenance

In order to maintain optimal performance, the spark arrestor screen should be cleaned after the first 3 hours of use. Afterwards, clean every 30-35 hours of use.



Figure 1



Figure 2



Figure 3



Figure 4

Clean-out Instructions:

Make sure the vehicle is “cool” before completing the clean-out procedure.

1. Using a 4mm hex key, remove the 4 screws securing the outlet cap or tip. **(Figure 1)**
2. Remove the outlet cap to expose the spark arrestor screen insert. **(Figure 2)**
3. Remove the screen insert. **(Figure 3)**
4. Using a wire brush, thoroughly brush the screen to remove residue. **(Figure 4)**
5. Replace the screen and cap.
6. Tighten the screws to 60 in-lbs (6.8 Nm).