

MBRP

AT-9525PT

MUFFLER ASSEMBLY, 5"

2017- 2024 POLARIS SPORTSMAN XP 1000 HIGH LIFTER

2017- 2024 POLARIS SPORTSMAN 850 HIGH LIFTER

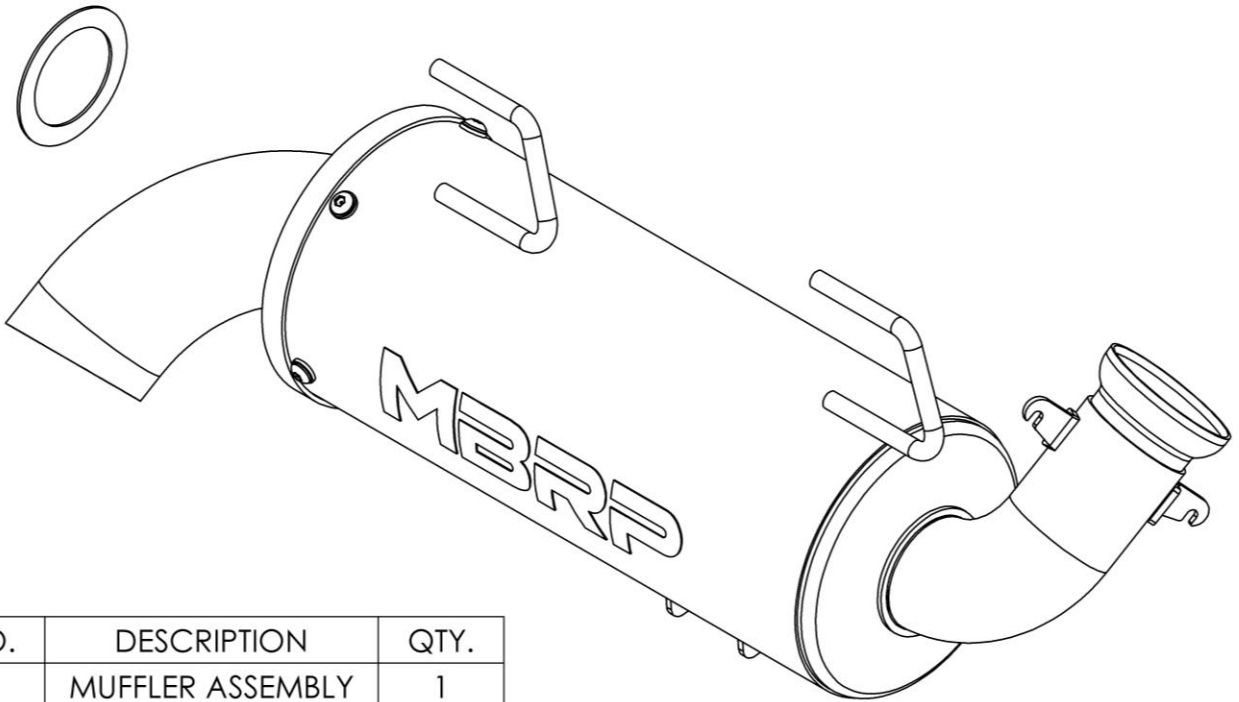

ITEM NO.	DESCRIPTION	QTY.
1	MUFFLER ASSEMBLY	1
2	RING INSERT	1

PLEASE READ BEFORE STARTING INSTALLATION

While MBRP Ltd. has made every effort to ensure that all components of this system are of superior quality and properly packaged, it is the installer's responsibility to ensure the following before removal of the factory exhaust:

- that ALL components shown above are present.
- that ALL mating components fit together.
- that there are no damaged components.
- that the system you have purchased is appropriate for your vehicle year, model and configuration.
- that the system will not interfere with any modifications previously installed or planned.
- that you have read and understand these instructions.

If you have any questions or are uncertain about any aspect of the installation of this system to your vehicle please contact your dealer before commencing installation.

MBRP



Figure 1



Figure 2



Figure 3



Figure 4



Figure 5

Removal of Stock Exhaust:

1. In order to remove the stock exhaust, the rear rack and storage compartment must be lifted slightly to allow the muffer hangers to clear the bottom of the storage compartment.
2. Remove the four (4) centre screws on the top of the rack as indicated in **Figure 1**, then open the rear compartment and remove the four (4) screws around the compartment opening as indicated in **Figure 2**.
3. Remove the two (2) bolts securing the small heat shield to the inlet of the stock muffer, then remove the two (2) springs securing the muffer inlet. **Refer to Figure 3**.
4. Remove the two (2) springs from the lower muffer mount.
5. Lift the rear compartment upwards and use a temporary spacer (refer to **Figure 4**) to hold it in the lifted position, then slide the muffer hangers out of the rubber isolators to remove the muffer. *Note: the front pipe may have to be held upward for the muffer inlet to clear it. If the inlet gasket came off the front pipe with the muffer, place it back onto the pipe to use with the new exhaust.

Installation of MBRP Exhaust:

1. With the rear compartment still lifted, slide the hangers on the new **Muffer Assembly** into the rubber isolator mounts (move the front pipe upward as needed to clear the muffer inlet).
2. Place the bottom bracket of the **Muffer Assembly** over the center locator and secure it into position by installing the two stock springs onto the bracket, then install the other two springs onto the muffer inlet. **Refer to Figure 5**.
3. Lower the rear rack and storage compartment back into place and replace the eight (8) screws that were removed previously.

It is recommended that the muffer screws be retightened after the first ride and checked periodically thereafter, tightening if necessary.

Note: This muffer utilizes a quiet insert (pre-installed) to limit sound levels. If increased exhaust flow is desired, replace the quiet insert with the **Ring Insert** by removing the muffer tip and the spark arrestor. Reinstall the spark arrestor with the **Ring Insert**. Note that tuning may be required for optimal performance with the increase in flow capacity.

Congratulations! You are ready to begin experiencing the improved performance and driving excitement of your MBRP ATV Exhaust upgrade. We know you will enjoy your purchase.



Figure 1



Figure 2



Figure 3



Figure 4

Spark Arrestor Maintenance

In order to maintain optimal performance, the spark arrestor screen should be cleaned after the first 3 hours of use. Afterwards, clean every 30-35 hours of use.

Clean-out Instructions:

Make sure the vehicle is cool before completing the clean-out procedure.

1. Using a 4mm hex key, remove the 4 screws securing the outlet cap or tip. **(Figure 1)**
2. Remove the outlet cap to expose the spark arrestor screen insert. **(Figure 2)**
3. Remove the screen insert. **(Figure 3)**
4. Using a wire brush, thoroughly brush the screen to remove residue. **(Figure 4)**
5. Replace the screen and cap.
6. Tighten the screws to 60 in-lbs (6.8 Nm).