

# AT-6502SP

SPORT MUFFLER-SLIP-ON, POLARIS  
2001-2013 SPORTSMAN 500 (ALL MODELS EXCLUDING TOURING)  
2014-UP SPORTSMAN 570 (ALL MODELS EXCLUDING CALIFORNIA  
AND CATTED VERSIONS)  
2001-2005 SPORTSMAN 400  
2011-2014 SPORTSMAN 400HO, HAWKEYE 400HO  
2006-2007, 2016-UP SPORTSMAN 450  
2017-UP SPORTSMAN 570 6X6 ( ALL MODELS EXCLUDING CALIFORNIA  
AND CATTED VERSIONS)  
2015 HAWKEYE 325/SPORTSMAN ETX

# MBRP<sup>®</sup>

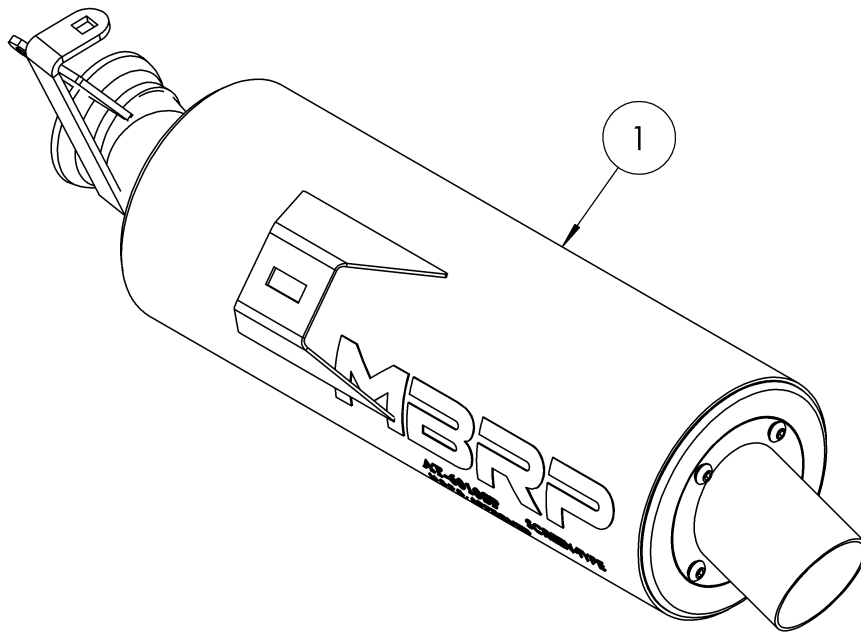

## 1. MUFFLER ASSEMBLY

### PLEASE READ BEFORE STARTING INSTALLATION

While MBRP Inc. has made every effort to ensure that all components of this system are of superior quality and properly packaged, it is the installer's responsibility to ensure the following before removal of the factory exhaust:

- that ALL components shown above are present.
- that ALL mating components fit together.
- that there are no damaged components.
- that the system you have purchased is appropriate for your vehicle year, model and configuration.
- that the system will not interfere with any modifications previously installed or planned.
- that you have read and understand these instructions.

If you have any questions or are uncertain about any aspect of the installation of this system to your vehicle please contact your dealer before commencing installation.

# MBRP

## Removal of Stock System

1. Remove the springs securing the main muffler inlet to the exhaust pipe. Do not discard the springs or the gasket.
2. Remove the bolts attaching the muffler to the vehicle and remove the muffler. Retain hardware for installation.



**Figure 1**

## Installation of MBRP Performance Exhaust:

1. Place the gasket that was previously removed onto the front pipe of the vehicle.

**Refer to Figure 1.**

2. Loosely Attach the Muffler brackets to the vehicle using the bolts that were previously removed.

**Refer to Figure 2.**

3. Position the **Muffler** inlet onto the end of the exhaust pipe and secure it using the springs previously removed. Tighten all the bolts for a secure fit.

**Refer to Figure 3.**

If a quieter tone is desired contact your local dealer to purchase T14373.

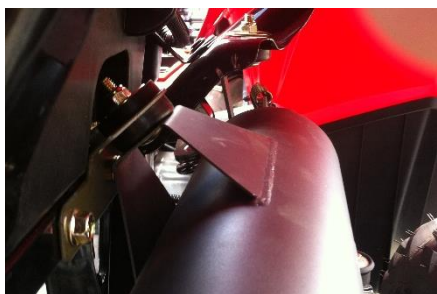

**Figure 2**



**Figure 3**



**Congratulations!** You are ready to begin experiencing the improved power, sound and driving experience of your **MBRP** performance exhaust system. We know you will enjoy your purchase.

# MBRP

## Spark Arrestor Maintenance

In order to maintain optimal performance, the spark arrestor screen should be cleaned after every 30-35 hours of use.

### Clean-out Instructions:

Make sure the vehicle is cool before completing the clean-out procedure.

1. Using a 1/8" hex key, remove the 4 screws securing the outlet cap. (Figure 1).
2. Remove the outlet cap to expose the spark arrestor screen insert. (Figure 2)
3. Remove the screen insert. (Figure 3)
4. Using a wire brush, thoroughly brush the screen to remove residue. (Figure 4)
5. Replace the screen and cap.
6. Tighten the screws to 23 in-lbs (2.6 Nm).



**Figure 1**



**Figure 2**



**Figure 3**



**Figure 4**