

AT-9527PT

SLIP-ON MUFFLER ASSEMBLY, 4"
2010 POLARIS RANGER 500EFI
2010-2017 POLARIS RANGER 800
(EXCLUDING 2013-2014 MID-SIZE)

MBRP®

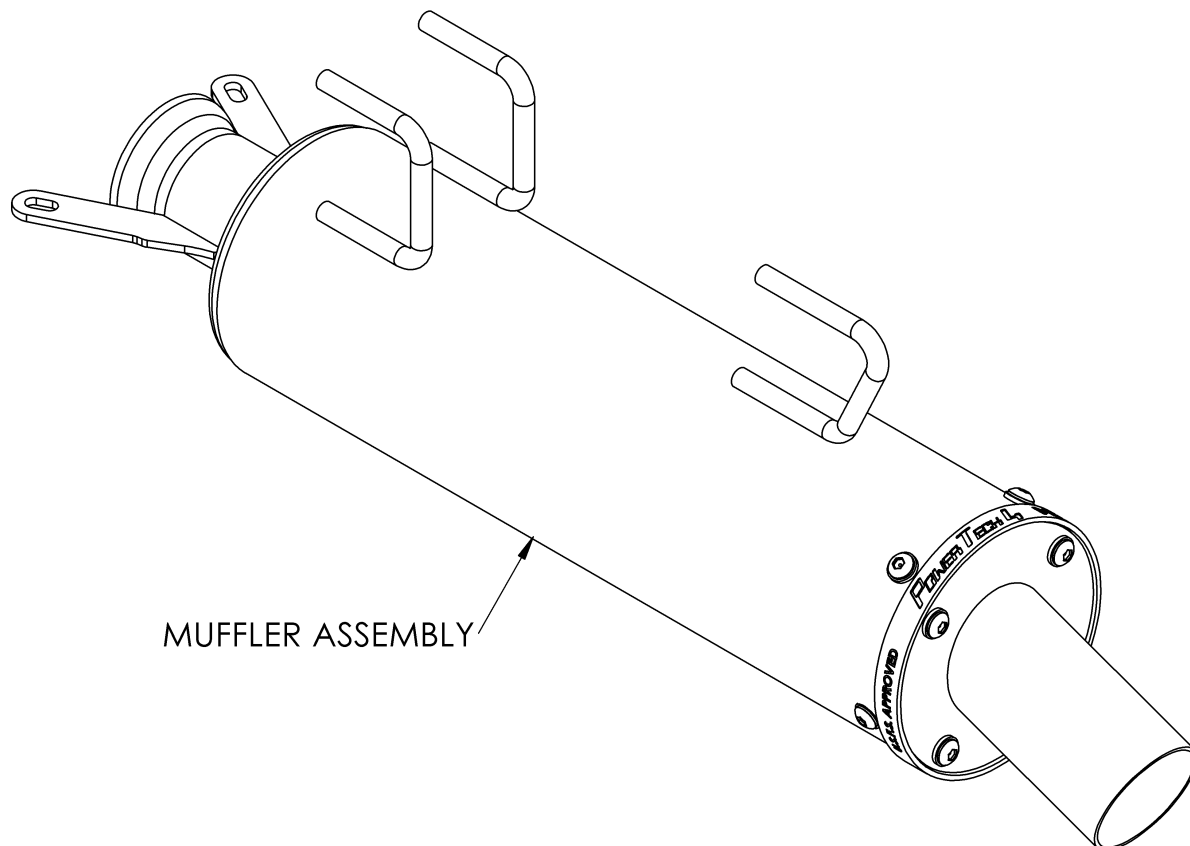

PLEASE READ BEFORE STARTING INSTALLATION

While MBRP has made every effort to ensure that all components of this system are of superior quality and properly packaged, it is the installer's responsibility to ensure the following before removal of the factory exhaust:

- that ALL components shown above are present.
- that ALL mating components fit together.
- that there are no damaged components.
- that the system you have purchased is appropriate for your vehicle year, model and configuration.
- that the system will not interfere with any modifications previously installed or planned.
- that you have read and understand these instructions.

If you have any questions or are uncertain about any aspect of the installation of this system to your vehicle please contact your dealer before commencing installation.

MBRP

Removal of Stock Exhaust:

CAUTION: THIS EXHAUST IS EXTREMELY HOT WHEN THE ENGINE HAS BEEN RUNNING. ALLOW THE EXHAUST TO FULLY COOL BEFORE PERFORMING THIS INSTALLATION.

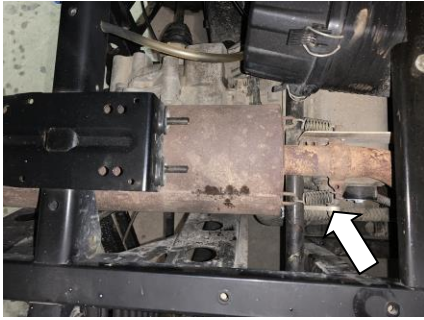

Figure 1



Figure 2

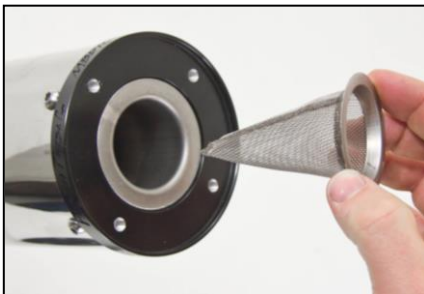

Figure 3

1. Raise the dump bed to gain access to the stock muffler.
2. Remove the springs mounting the stock muffler to the pipe. **Refer to Figure 1.**
3. Apply a penetrating lubricant to the hangers to ease removal.
4. Lower the dump bed and slide the muffler out from the rear.

Installation of MBRP Exhaust:

1. Slide the **Muffler Assembly** hangers into the factory isolators and re-install the factory springs. **Refer to Figure 2.**

Note: to prevent melting avoid running the vehicle while the dump bed is in the up position.

It is recommended that the muffler end cap screws be retightened after the first ride and checked periodically thereafter, tightening if necessary.

In order to maintain optimal performance, the spark arrestor screen should be cleaned after the first 3 hours of use. Afterwards, clean every 30-35 hours of use. The spark arrestor can be accessed by removing the four (4) screws and outlet tip. Tighten the screws to 60in-lbs (6.8Nm) when reassembling. **Refer to Figure 3.**



Congratulations! You are ready to begin experiencing the improved performance, sound and driving experience of your **MBRP** performance exhaust system. We know you will enjoy your purchase.