

# S5074

09-12 CHEV COLORADO/GMC  
CANYON, 5.3L,  
EXTENDED/CREW CAB-SHORT  
BOX, CAT BACK,

# MBRP

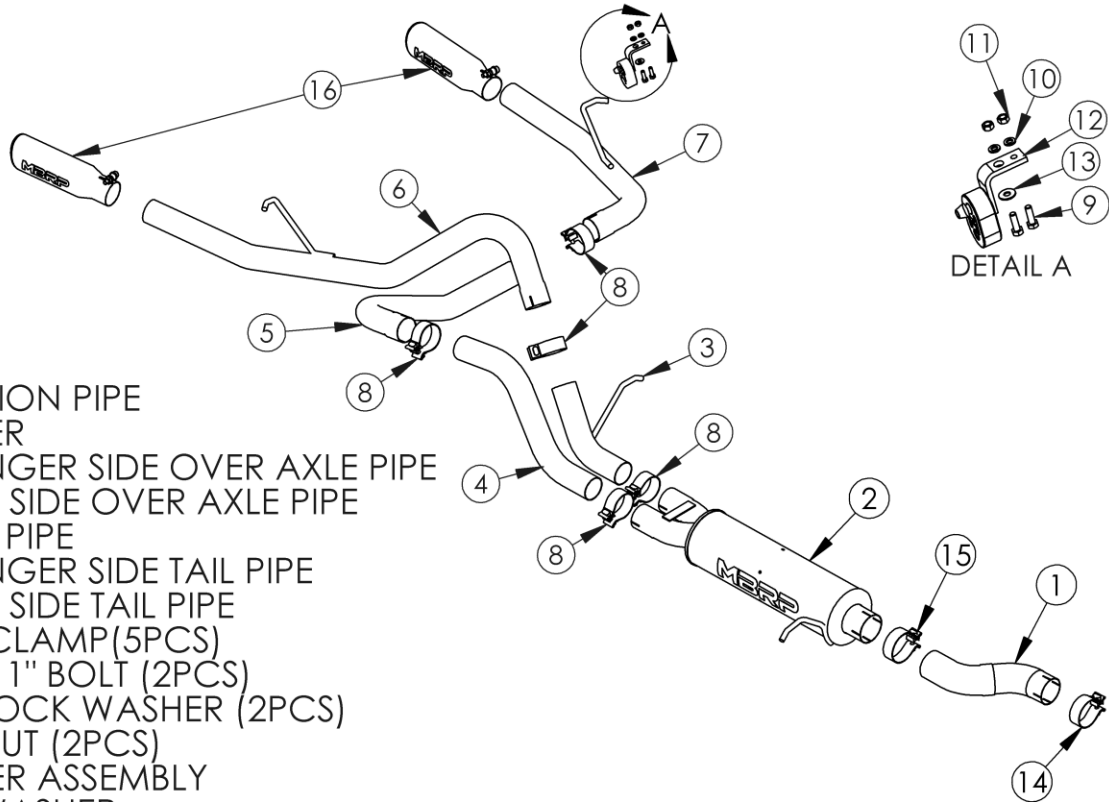

1. EXTENSION PIPE
2. MUFFLER
3. PASSENGER SIDE OVER AXLE PIPE
4. DRIVER SIDE OVER AXLE PIPE
5. CROSS PIPE
6. PASSENGER SIDE TAIL PIPE
7. DRIVER SIDE TAIL PIPE
8. 2 1/2" CLAMP (5PCS)
9. 5/16" X 1" BOLT (2PCS)
10. 5/16" LOCK WASHER (2PCS)
11. 5/16" NUT (2PCS)
12. HANGER ASSEMBLY
13. 5/16" WASHER
14. 2 3/4" CLAMP
15. 3" CLAMP
16. EXHAUST TIP (2PCS)
17. NOTE: SPARE TIRE REMOVAL IS REQUIRED FOR THIS SYSTEM

## PLEASE READ BEFORE STARTING INSTALLATION

While MBRP Inc. has made every effort to ensure that all components of this system are of superior quality and properly packaged, it is the installer's responsibility to ensure the following before removal of the factory exhaust:

- that ALL components shown above are present.
- that ALL mating components fit together.
- that there are no damaged components.
- that the system you have purchased is appropriate for your vehicle year, model and configuration.
- that the system will not interfere with any modifications previously installed or planned.
- that you have read and understand these instructions.

If you have any questions or are uncertain about any aspect of the installation of this system to your vehicle please contact your dealer before commencing installation.

# MBRP



**Figure 1**



**Figure 2**



**Figure 3**



**Figure 4**

**Note: This System requires spare tire removal**

## **Removal of Stock System:**

1. Apply a penetrating lubricant liberally to all exhaust fasteners, hangers and rubber insulators.
2. Cut the exhaust in rear of the muffler so that the tail section can be removed from the vehicle.
3. Measure 4 1/2" in front of the cross member. The cross member is located just behind the Y-pipe. **Refer to Figure 2.**
4. Remove the hangers from the rubber insulators. Remove the exhaust from the vehicle. **Refer to Figure 3.**
5. Remove spare tire from the vehicle and relocate.

## **Installation of MBRP Inc. Performance Exhaust:**

1. Install the **Extension Pipe** to the end of the Y-pipe using the 2 3/4" **Clamp**. **Refer to Figure 4.**

# MBRP



**Figure 5**

2. Slide a 2 ½” **Clamp** over the **Extension Pipe** and install the **Muffler Assembly** onto the **Extension Pipe**. Using another 2 ½” **Clamp** slide the **Passenger Side Over Axle Pipe** into the driver side of the **Muffler Assembly**. Attach the two hangers into to the existing rubber insulator at the front and back of the **Muffler Assembly**. **Refer to Figure 5**.

Note: Driver side of **Muffler Assembly** leads to **Passenger Side Tailpipe** and vice versa.



**Figure 6**

3. Slide a 2 ½” **Clamps** over the outlet of the **Passenger Side Over Axle Pipe**. Position the **Passenger Side Tail Pipe** and loosely attach it to the **Passenger Side Over Axle Pipe**. Install the **Passenger Side Tail Pipe** hanger into the existing rubber insulator. **Refer to Figure 6**.

4. Loosely install the **Driver Side Over Axle Pipe** to the passenger side of the **Muffler**.

**Refer to Figure 7**.



**Figure 7**

5. Slide a 2 ½” **Clamp** over the **Driver Side Over Axle Pipe** then loosely attach the **Cross Pipe** to the **Driver Side Over Axle Pipe**.

**Refer to Figure 8**.



**Figure 8**

6. Install the **Hanger Assembly** using the fasteners provided. Note some vehicles may require drilling to enlarge the one hole.

**Refer to Figure 9**.



**Figure 9**

# MBRP



**Figure 10**

7. Slide a 2 ½” **Clamp** onto the **Cross Pipe** and then attach the **Driver Side Tail Pipe** hanger into the **Hanger Assembly** and to the **Cross Pipe**. Refer to **Figure 10**.

8. Install and adjust the **Exhaust Tips** to suit. Tighten the lock bolt located on each **Exhaust Tip**. Refer to **Figure 11**.



**Figure 11**

9. Carefully align the system and tips. Align the edge of each band clamp with the edge of the joint it is connecting. Tighten all hardware and clamps, starting at the front and working rearward to secure the system. Check along the full length of the exhaust system to ensure there is adequate clearance for fuel lines, vent lines, brake lines, frame, bodywork, suspension and any wiring, etc. If there is any interference detected, relocate or adjust to provide adequate clearance. Ensure all clamp connections are secure and components are unable to rotate or slide. Band clamps require approximately 45 lb-ft (60 N-m) of torque. Verify clearances, system security and band clamp torque after 30-60 miles (50-100 km) of driving.



**Congratulations!** You are ready to begin experiencing the improved power, sound and driving experience of your MBRP Inc. performance exhaust system. We know you will enjoy your purchase.