

PRIMARY APPLICATION

NISSAN

Titan 4x2 (2016-2020)
NON-XD models only.

Titan 4x4 (2016-2020)
NON-XD models only.

TOOLS REQUIRED

- 1 Floor Jack
- 2 Jack Stands
- 4 Wheel Blocks
- 1 5mm Allen Wrench

PARTS LIST

Item	QTY	Part#	Description
A	2	512012	Mounting Plate
B	2	512267	M8 x 35mm FHCS
C	2	511440	SumoSprings Blue (-40)
D	1	512239	Loctite sachet

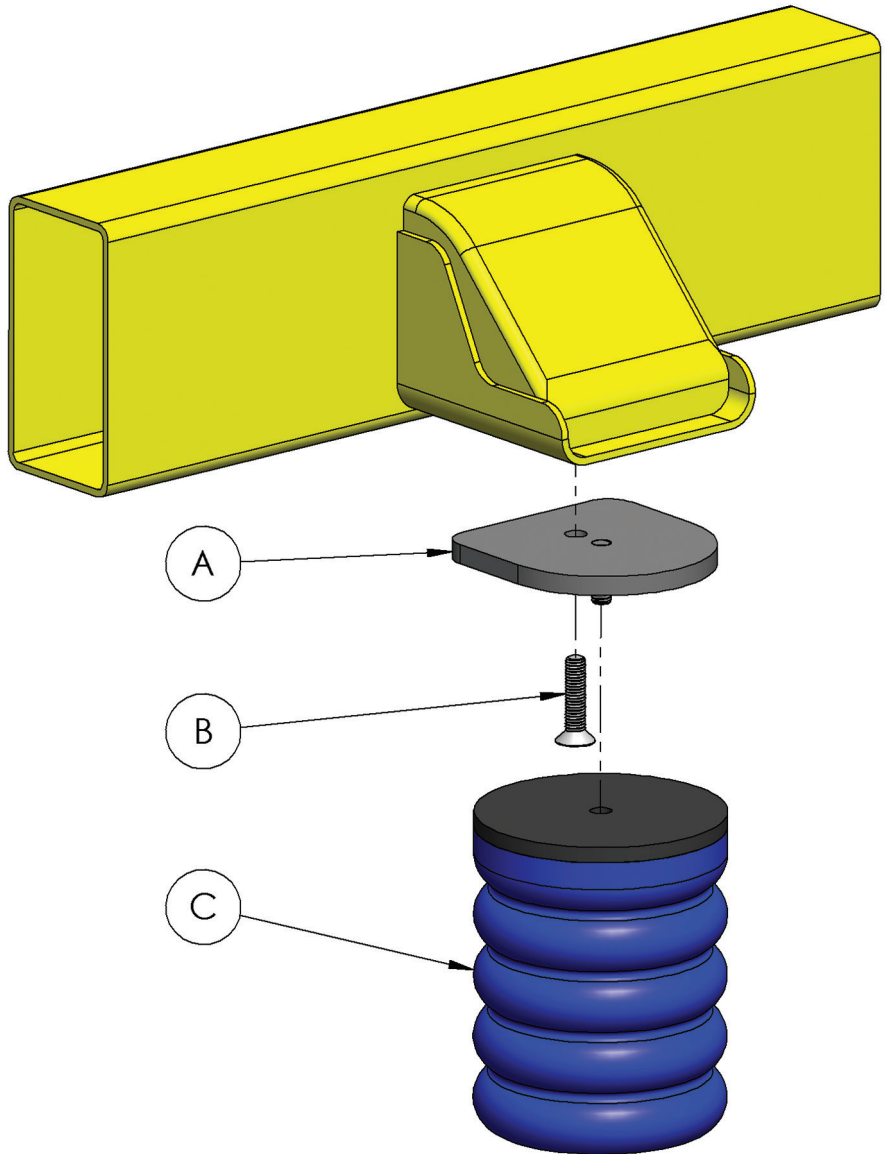

APPROXIMATE INSTALL TIME

🕒 1 Hour

SuperSprings International, Inc.

505 Maple Avenue
Carpinteria, CA 93013

Technical Support

+1 (805) 745-5553
tech@supersprings.com

supersprings.com

Never exceed the manufacturer's Gross Vehicle Weight Rating (GVWR) located on your vehicle's identification tag.

SAFETY NOTICE: We recommend installation be done by a professional or persons with sound mechanical knowledge.

WARNING: These instructions are a general guide for installation. SuperSprings International, Inc. assumes no liability for the actual installation process. Consumers and installers should apply common automotive safety practices when raising and working on any vehicle. **Do not put yourself in a position where, if the vehicle were to move**

unexpectedly, you may be injured. SuperSprings' products are designed to improve vehicle ride quality. Do not load any vehicle beyond the manufacturer's specifications.

BEFORE INSTALLATION: Ensure the vehicle is on a level surface, the parking brake is ON, with the ignition OFF, and place blocks in front of and behind the front tires to prevent the vehicle from moving.

DURING AND/OR AFTER INSTALLATION: Ensure emergency brake cables are not touching the SuperSprings. Secure any cables out of the way with zip ties or by re-routing. **Ensure all A/C lines, brake cables and frame are clear of contact or interference.**

1. Park vehicle on level hard surface. Engage emergency brake. Place blocks in front and behind front wheels to prevent rolling. Observe all safety precautions and wear safety glasses.
2. Raise rear of vehicle allowing the axle to hang freely. Support the frame using safety jack stands.
3. Remove existing factory jounce bumper assembly by pulling/twisting the bumper out of the steel cup and then unbolt the steel cup from the frame.
4. Insert the **M8 x 35mm flat head cap screw (ITEM B)** through the countersunk hole in the **mounting plate (ITEM A)**.
5. Put a drop of blue **Loctite (ITEM D)** on the threads of the bolt.
6. Using a 5mm Allen wrench, thread the bolt into the existing hole in the frame and tighten to 20 ft. lbs.

NOTE: Ensure that the rounded side of the **mounting plate (ITEM A)** is facing out toward the wheel.

7. Put a drop of blue **Loctite (ITEM D)** on the threads of the Mounting Plate stud and thread the **SumoSprings Blue [-40] (ITEM C)** onto the stud. Tighten firmly by hand.
8. Repeat procedure on the other side.
9. Raise the vehicle, remove safety jack stands.
10. Carefully lower vehicle to the hard surface. Remove the blocks in front and back of the rear wheels.
11. Release emergency brake.
12. Fill out warranty information at: supersprings.com/warranty/

SuperSprings International, Inc.

505 Maple Avenue
Carpinteria, CA 93013

Technical Support

+1 (805) 745-5553
tech@supersprings.com

supersprings.com



Never exceed the manufacturer's Gross Vehicle Weight Rating (GVWR) located on your vehicle's identification tag.

SAFETY NOTICE: We recommend installation be done by a professional or persons with sound mechanical knowledge.

WARNING: These instructions are a general guide for installation. SuperSprings International, Inc. assumes no liability for the actual installation process. Consumers and installers should apply common automotive safety practices when raising and working on any vehicle. **Do not put yourself in a position where, if the vehicle were to move**

unexpectedly, you may be injured. SuperSprings' products are designed to improve vehicle ride quality. Do not load any vehicle beyond the manufacturer's specifications.

BEFORE INSTALLATION: Ensure the vehicle is on a level surface, the parking brake is ON, with the ignition OFF, and place blocks in front of and behind the front tires to prevent the vehicle from moving.

DURING AND/OR AFTER INSTALLATION: Ensure emergency brake cables are not touching the SuperSprings. Secure any cables out of the way with zip ties or by re-routing. **Ensure all A/C lines, brake cables and frame are clear of contact or interference.**