

# SumoSprings Rear

Mercedes Sprinter 3500 4X4 (2016-Present)

Part #SSR-339-40-2 & SSR-339-47-2

## DRIVER'S SIDE

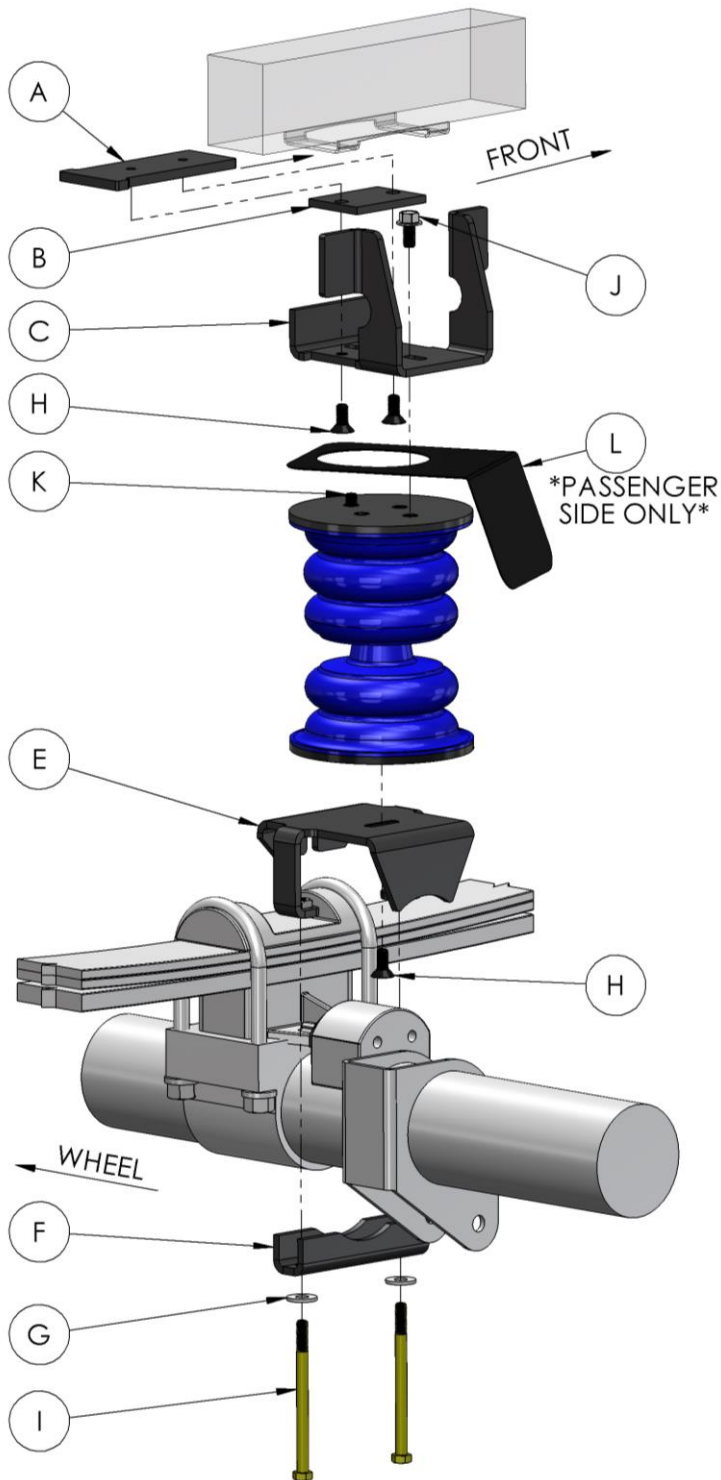

## Tool List

Floor Jack	1
Jack stands	2
Wheel blocks	4
9/16" wrench	2
9/16 socket wrench	1
7/32 Allen key	1

## Parts List

Item	Part #	Description	Qty.
A	512082	Br-R Sprint 3500 Upper clamp	2
B	512083	Br-R Sprint 3500 Spacer plate	2
C	512132	Brkt Sprinter 3500 4x4 rr top	2
D	511419	Air Spring K6060-40-2	2
E	512131	Brkt Sprinter 3500 4x4 rr bttm	2
F	512021	Sumo under axle bracket	2
G	512227	3/8 USS Flat Washer - Steel	4
H	512245	3/8-16 x 7/8 FHCS capscrew	6
I	512343	3/8-16x5" Hex bolt Gr8	4
J	512207	3/8-16 x 3/4in Serr Flange bolt	2
K	512263	3/8-16 x 3/4in socket setscrew	2
L	512078	Br-R Sprint 2500 Heat shield (For passenger side only)	1

20161214

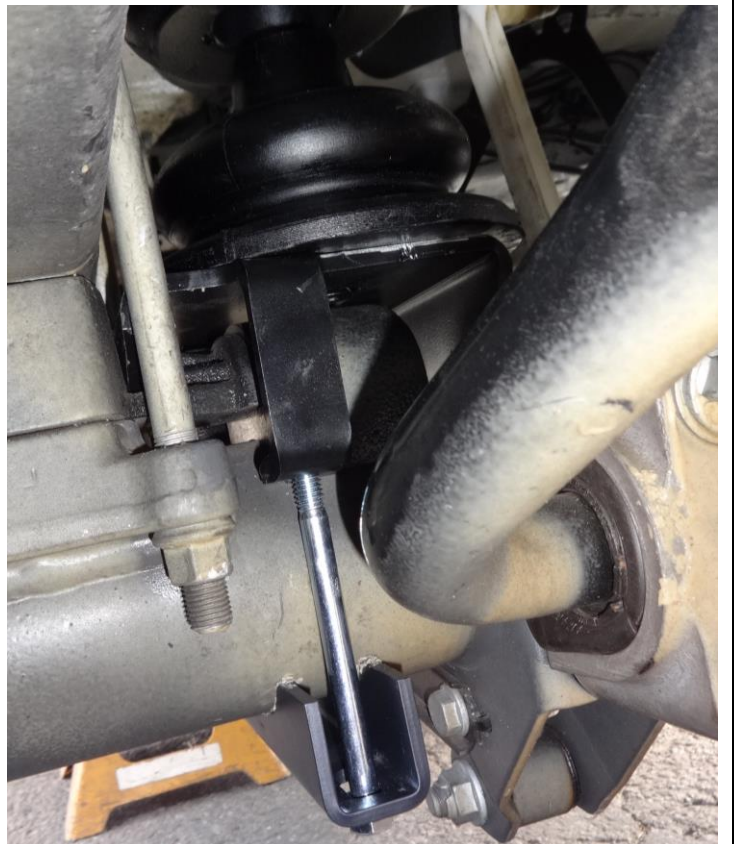

## **Installation Instructions**

**\*Note: Please read all instructions and refer to diagram on the front and included pictures before beginning installation\***

- 1) Park vehicle on level hard surface. Place wheel blocks in front and behind the front wheels to prevent rolling. Observe all safety precautions and wear safety glasses.
- 2) Raise the rear of the vehicle allowing the axle to hang free and rest the frame on the safety jack stands rated for the vehicle. Removal of the rear wheels is optional.
- 3) Starting on the driver's side. Remove the factory jounce bumpers from the underside of the frame and set aside. These can be removed by pulling sideways firmly and rotating them out of the holders.
- 4) Remove the upper bracket assembly items A (part #512082), B (part #512083) and C(part #512132) from the box. Slide the upper T-bracket (Item A #512082) into the bump-stop holder bracket underside the frame from the rear. Attach the upper frame bracket (Item C #512132) and upper spacer (Item B #512083) to the upper T-bracket using two 3/8-16 x 7/8" flat head cap-screws (Item H). Use the supplied loctite and secure tightly. Ensure you orientate the upper frame bracket with the two vertical flanges inside the frame away from the wheel.
- 5) Remove the lower bracket assembly parts E (Part #512131) and F (Part #512021) from the box. Then attach the Lower Bracket E to the lower (male) half of the Sumospring using a 3/8-16 x 7/8" flat head cap-screw (Item H). DO NOT apply Loctite at this stage and leave the bolt slightly loose to allow for alignment with upper half of Sumospring.
- 6) Install the setscrew Item K into one of the holes of the wider bolt pattern on top of the upper (female) half of the Sumospring so that it is sticking out 3/16 of an inch.
- 7) Set the upper half of the Sumospring on top of the lower and place the assembly on the driver's side axle housing with the lower bracket outboard cut-out located on the flange that extends from the spacer block between the factory u-bolts and against the factory spring-pack.
- 8) Align the setscrew Item K with the outer hole in the upper bracket and bolt the upper half of the Sumospring to the upper bracket using one 3/8-16 x 3/4" serrated flange head bolt Item J. Before tightening the bolt, align the upper and lower halves of the Sumospring.
- 9) After aligning the Sumospring halves, tighten the upper bolt and use a marker or scribe to mark the location of the lower half on the lower bracket. Remove the lower assembly from the axle, apply Loctite to the bolt and securely fasten it in the correct position.
- 10) Attach the lower bracket assembly to the axle using the under axle bracket (Item F) and two 3/8-16 x 5" hex bolts (Item I) and two 3/8 USS washers (Item G). Apply Loctite to the bolt threads and tighten securely but take care not to over tighten and bend the lower Sumospring bracket.
- 11) Repeat steps three through ten on the passenger's side of the vehicle. Be sure to install the exhaust heat shield Item L between the upper bracket and Sumospring and position accordingly.
- 12) If rear wheels were removed you can now reinstall the rear wheels.
- 13) Jack up vehicle, remove safety jack stands and carefully lower the vehicle to the hard surface.
- 14) Remove wheel blocks from the front wheels.
- 15) Fill out warranty card and send to SuperSprings. The warranty card is an attached document.

**Important Notice.**

- 1) For easy installation please read instructions completely first and have all necessary tools available.
- 2) We recommend that this installation be done by a professional or persons with sound mechanical knowledge.
- 3) SumoSprings are designed to work with the original factory springs only. If they have been replaced with aftermarket springs then please consult with Supersprings International at 866-898-0720.
- 4) These instructions are meant as a guide for the installation of SumoSprings. SuperSprings International assumes no liability for the actual installation process. Installers should apply common automotive safety practices when raising, lowering and working on vehicles.
- 5) SumoSprings are designed to enhance the vehicles load carrying performance and road handling however it does not authorize or recommend loading beyond the manufacturer's GVWR specifications.
- 6) For technical support contact SuperSprings International at 866-898-0720.

***To prevent damage to the vehicle and to ensure safety, do not exceed the maximum load recommended by the vehicles manufacturer (GVWR).***