

# MAGNAFLOW

Mufflers, Converters,  
Systems and Tips

Performance  
EXHAUST

## INSTALLATION INSTRUCTIONS FOR 16829

1983 – 1992 GM Camaro / Firebird V8

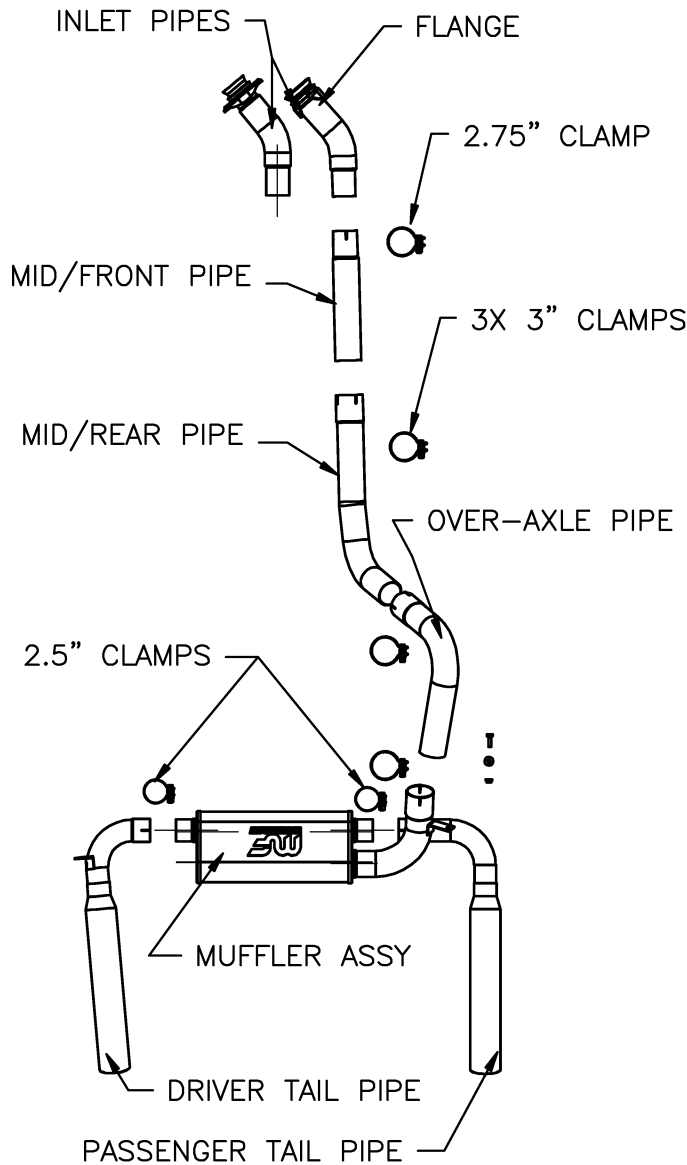

**Warning:** When working on, under, or around any vehicle exercise caution. Please allow the vehicle's exhaust system to cool before removal, as exhaust system temperatures may cause severe burns. If working without a lift, always consult vehicle manual for correct lifting specifications. Always wear safety glasses and ensure a safe work area. Serious injury or death could occur if safety measures are not followed.

**Step 1: (Carefully read all instructions before installation)** Disconnect the vehicle's battery before removal of the OEM exhaust. This will allow the computer to reset itself with the new system, and prevent electrical accidents. To remove the OEM exhaust system you will need to cut the OEM over-axle pipe just in front of the rear axle. Unbolt all hangers on the tailpipes and muffler, then remove from the vehicle (Do not damage the OEM rubber insulators or discard the OEM fasteners as they will be re-used to mount the new system.) Unbolt the clamp where the OEM middle pipe meets the catalytic converter extension and remove the pipe from the vehicle. On dual converter models unbolt clamp at the Y-pipe.

**Step 2:** Layout all parts of the new system as shown in the diagram. Install the OEM Muffler Extension pipe hanger brackets. Use supplied fasteners to attach bracket to hanger to align with the rubber insulator (See Fig # 1). Select appropriate inlet pipe and install the new inlet pipe by bolting it to the catalytic converter using the OEM fasteners at the 2-bolt flange (Leave all clamps and fasteners loose for final adjustment of the complete system). On the dual converter models bolt the front mid pipe directly to the Y-pipe. Install the new rear mid-pipe using a supplied 3.00" U-clamps. Working rearward, install the over-axle pipe using the supplied clamps, and the OEM fasteners from the hangers. Install the tailpipes by fitting the welded hangers into the rubber insulators. Mount the muffler to the over-axle pipe and the tailpipes using the supplied clamps and rubber insulators.

**Step 3:** With all components mounted loosely, adjust the system for overall aesthetics and clearance of frame & bodywork. (MAGNAFLOW recommends at least 1/2" of clearance between the exhaust system and any body panels to prevent heat-related body damage or fire.)

**\*MAGNAFLOW Performance Exhaust recommends professional installation on all their products**

Technical support: 1-800-959-9226 ext. 4500

MAGNAFLOW Performance Exhaust – 22961 Arroyo Vista – Rancho Santa Margarita, CA 92688

# MAGNAFLOW

Mufflers, Converters,  
Systems and Tips

*Performance*  
EXHAUST

INSTALLATION INSTRUCTIONS  
FOR 16829

1983 – 1992 GM Camaro / Firebird V8

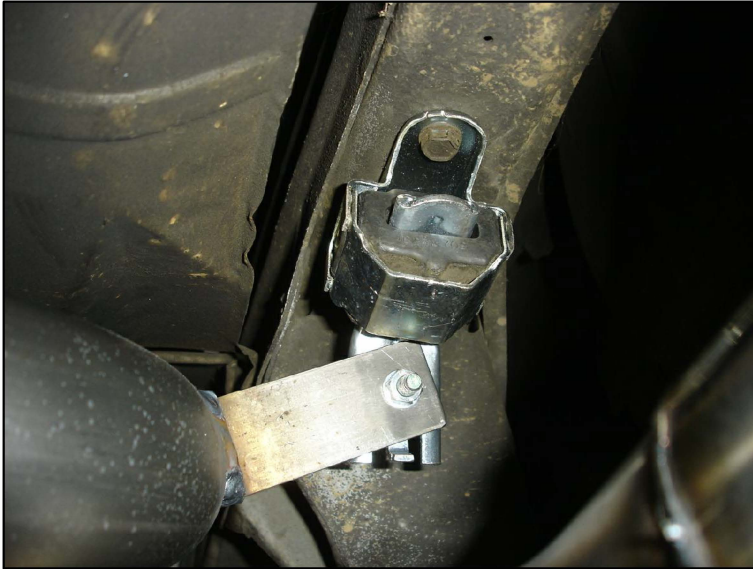

Fig # 1

**Warning:** When working on, under, or around any vehicle exercise caution. Please allow the vehicle's exhaust system to cool before removal, as exhaust system temperatures may cause severe burns. If working without a lift, always consult vehicle manual for correct lifting specifications. Always wear safety glasses and ensure a safe work area. Serious injury or death could occur if safety measures are not followed.

**Step 4:** Once a final position has been chosen for the new system, evenly tighten all fasteners from front to rear. You can now connect the battery, start the vehicle, and check for leaks. Inspect all fasteners after 25-50 miles of operation and retighten if necessary.

**\*MAGNAFLOW Performance Exhaust recommends professional installation on all their products**

Technical support: 1-800-959-9226 ext. 4500

MAGNAFLOW Performance Exhaust – 22961 Arroyo Vista – Rancho Santa Margarita, CA 92688