



INSTALLATION INSTRUCTIONS



'15 CHEVY COLORADO/GMC CANYON 2.5L/3.6L | PART NO. 19018

BILL OF MATERIALS:

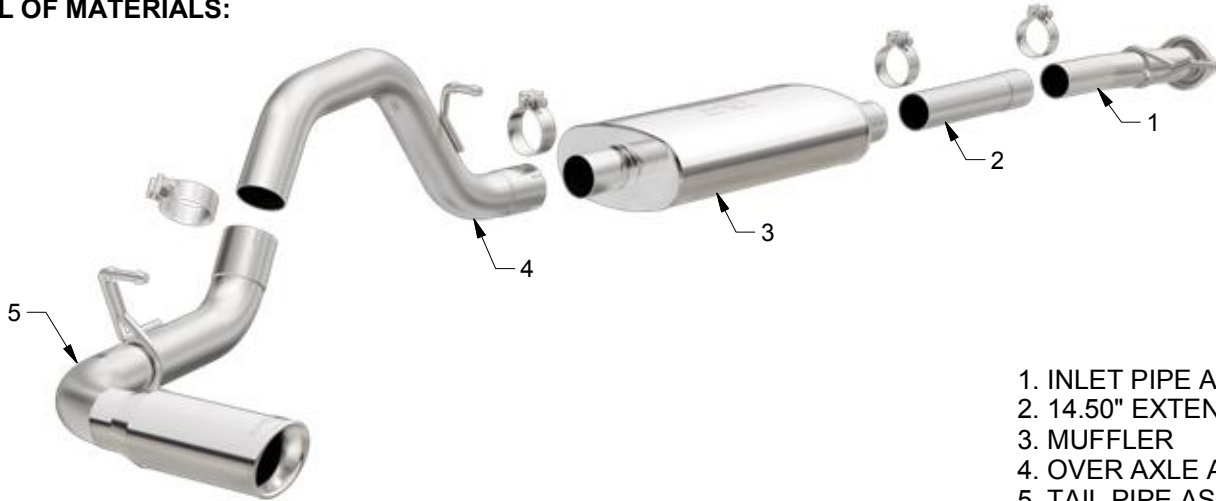

- 1. INLET PIPE ASSEMBLY
- 2. 14.50" EXTENSION PIPE
- 3. MUFFLER
- 4. OVER AXLE ASSEMBLY
- 5. TAIL PIPE ASSEMBLY



WEAR SAFETY GLASSES



READ INSTRUCTIONS THOROUGHLY BEFORE INSTALLING PRODUCT

SHOP SUPPLIES:



SPRAY LUBRICANT

To ease removal of existing exhaust components (especially on older vehicles) spray penetrating lubricant on all fasteners and hangers/insulators that will be loosened or removed and let soak before disassembly.

HARDWARE KIT:

- 1. [4] 3.00" Torca Clamp

MINIMUM REQUIRED TOOLS:



Hanger Tool (Or Pry Bar)



15mm
13mm

MAGNAFLOW RECOMMENDS PROFESSIONAL INSTALLATION ON ALL THEIR PRODUCTS



WARNING: When working on, under, or around any vehicle exercise caution. Please allow the vehicle's exhaust system to cool before removal, as exhaust system temperatures may cause severe burns. If working without a lift always consult vehicle manual for correct lifting specifications. Always wear safety glasses and ensure a safe work area. Serious injury or death could occur if safety measures are not followed.

ATTENTION: Always install any supplied band or U-bolt clamps to the proper torque specifications of 40-45 ft-lbs for band clamps and 30-35 ft-lbs for U-bolt clamps. Over tightening will result in the clamp breaking and will NOT be warranted by MagnaFlow.

INSTALLATION INSTRUCTIONS

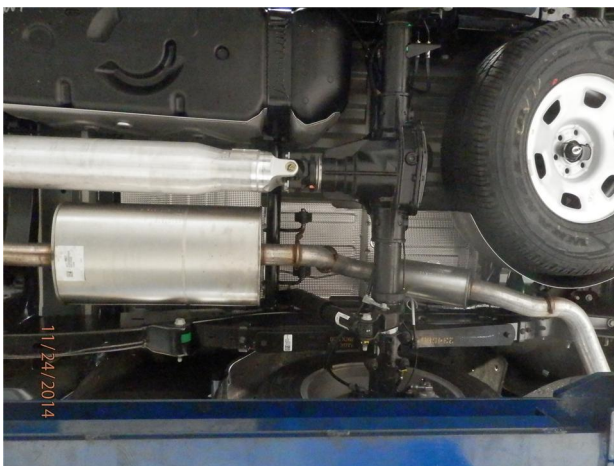
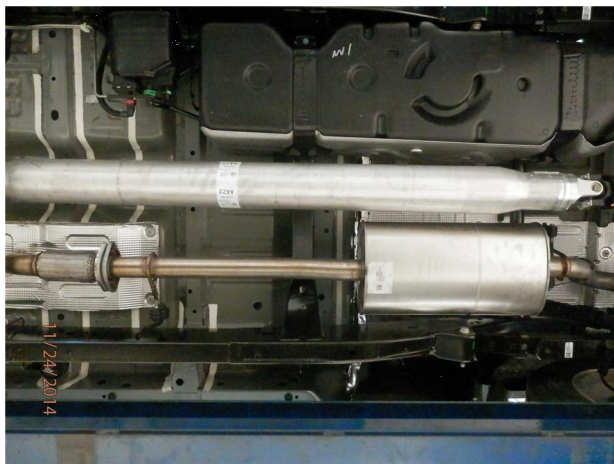

Step 1. To remove the OEM system you will need to unfasten the two bolt flange located behind the flex pipe. Working rearward (with the exhaust supported) extract the hangers from the rubber insulators and remove the OEM exhaust. Do not discard or damage the rubber insulators or fasteners as they will be used to install the new exhaust system.



Step 2. Begin installing of the new system by attaching the Inlet Pipe Assembly to the flange re-using the OEM fasteners and inserting the hanger into the rubber insulator.



Step 3. If your vehicle has a Crew Cab with a Standard Bed configuration you will need to include the supplied 14.50" Extension Pipe between the Inlet Pipe Assembly and the Muffler. For Crew Cab/Short Bed and Extended Cab/Standard Bed the Extension Pipe is omitted. Next loosely attach the Muffler to the Inlet Pipe Assembly or the Extension Pipe using a supplied 3.00" clamps.

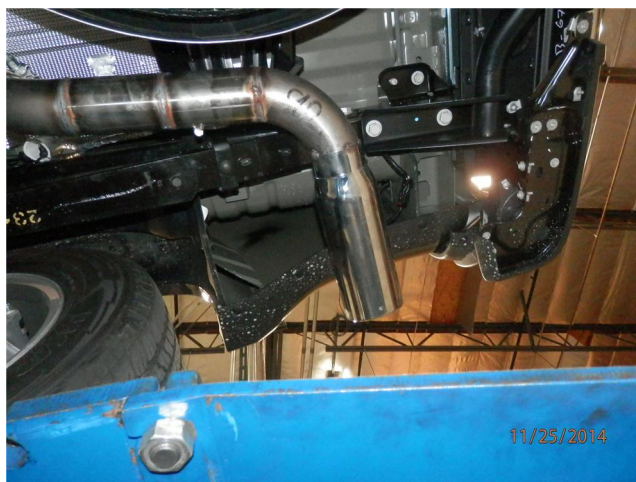

Step 4. Complete the installation by attaching the Tail Pipe Assembly to the Muffler using a supplied 3.00" clamp and inserting the hanger into the rubber insulator.

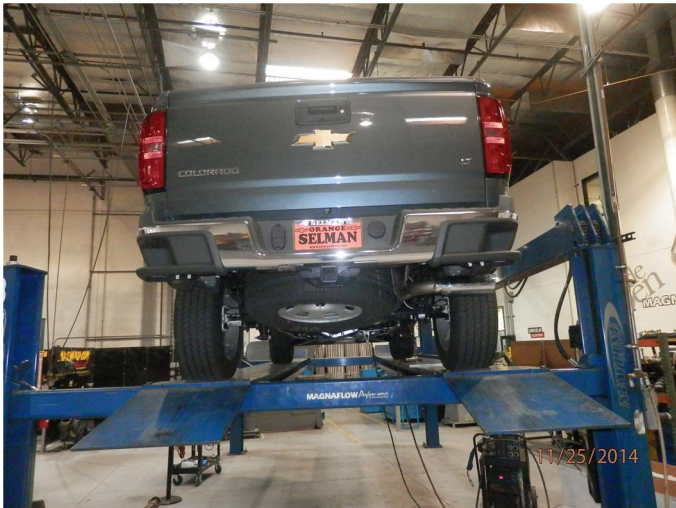

Step 5. Once a final position has been chosen for the new exhaust system, evenly tighten all clamps from front to rear using the torque specifications on page one of the instructions. Inspect all fasteners after 25-50 miles of operation and re-tighten if necessary.