

2011 Volkswagen Jetta S 2.0L

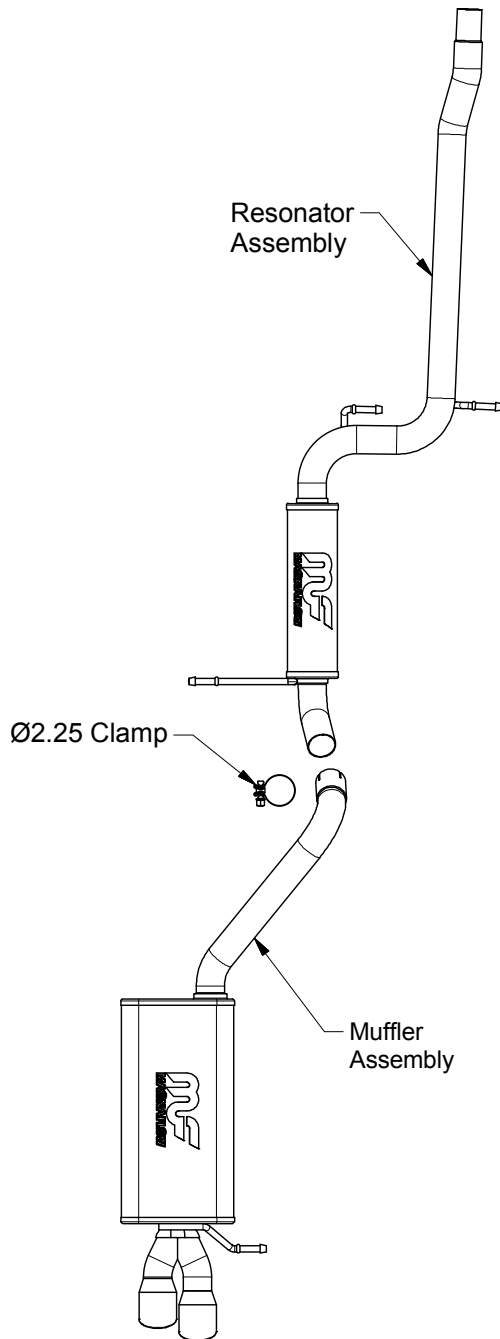

Warning: When working on, under, or around any vehicle exercise caution. Please allow the vehicle's exhaust system to cool before removal, as exhaust system temperatures may cause severe burns. If working without a lift, always consult vehicle manual for correct lifting specifications. Always wear safety glasses and ensure a safe work area. Serious injury or death could occur if safety measures are not followed.

Step 1:(Carefully read all instructions before installation) Remove the OEM exhaust system by loosening the OEM clamp on the catalytic converter outlet extension pipe. Working front to rear remove all welded hangers from the rubber isolators. Be sure to retain all mounting hardware as it will be needed to install your new MAGNAFLOW performance exhaust system.

Step 2: To install your new system insert the inlet end of the resonator assembly into the outlet of the catalytic converter extension pipe. Loosely secure using the OEM clamp. Next slip the inlet pipe of the muffer assembly over the outlet pipe of the resonator assembly and loosely secure using the supplied clamp. Locate all welded hangers to the rubber isolators.

Step 3: With all components mounted loosely, adjust the system for overall aesthetics and clearance of frame & bodywork. (MAGNAFLOW recommends at least 1/2" of clearance between the exhaust system and any body panels to prevent heat-related body damage or fire.)

Step 4: Once a final position has been chosen for the new system, evenly tighten all fasteners from front to rear. The supplied band clamps must be VERY tight to properly align the pipes and prevent leaks (Approximately 40ft-lbs). U-bolt clamps should be tightened to approximately 30-35ft-lbs. Inspect all fasteners after 25-50 miles of operation and retighten if necessary.

**** Magnaflow Performance Exhaust recommends professional installation on all their products**