



INSTALLATION INSTRUCTIONS



2016 BMW 340i 3.0L

PART NO. 19297

BILL OF MATERIALS:

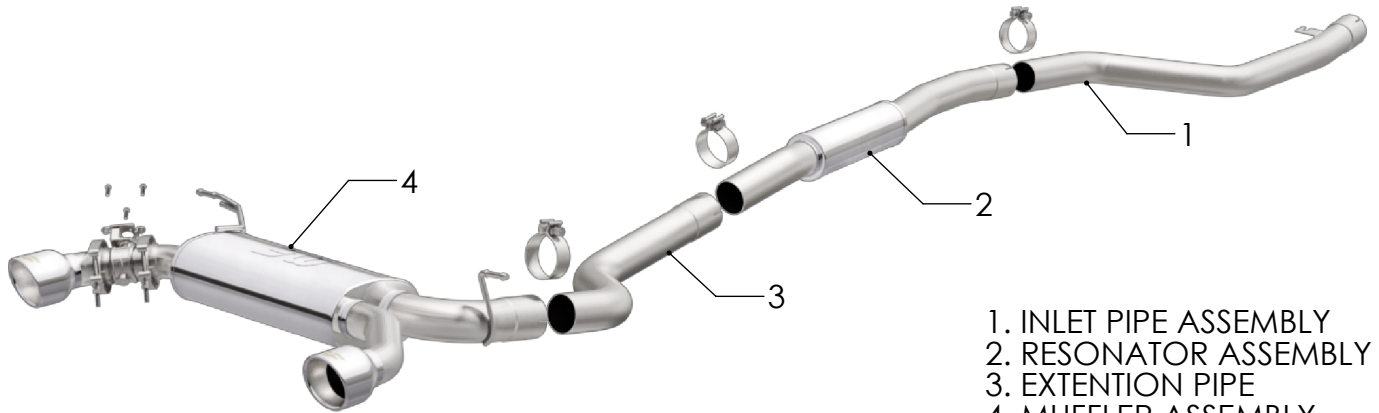

- 1. INLET PIPE ASSEMBLY
- 2. RESONATOR ASSEMBLY
- 3. EXTENTION PIPE
- 4. MUFFLER ASSEMBLY



WEAR SAFETY GLASSES



READ INSTRUCTIONS THOROUGHLY BEFORE INSTALLING PRODUCT



SPRAY LUBRICANT

To ease removal of existing exhaust components (especially on older vehicles) spray penetrating lubricant on all fasteners and hangers/insulators that will be loosened or removed and let soak before disassembly.

HARDWARE KIT:

- 1. [3] 3.00" Clamp

MINIMUM REQUIRED TOOLS:



13,15 mm T47 Torq



Hanger Tool (Or Pry Bar)

MAGNAFLOW RECOMMENDS PROFESSIONAL INSTALLATION ON ALL THEIR PRODUCTS



WARNING: When working on, under, or around any vehicle exercise caution. Please allow the vehicle's exhaust system to cool before removal, as exhaust system temperatures may cause severe burns. If working without a lift always consult vehicle manual for correct lifting specifications. Always wear safety glasses and ensure a safe work area. Serious injury or death could occur if safety measures are not followed.

ATTENTION: Always install any supplied band or U-bolt clamps to the proper torque specifications of 40-45 ft-lb for band clamps and 30-35 ft-lb for U-bolt clamps. Over tightening will result in the clamps breaking and will NOT be warranted by MagnaFlow.

MAGNAFLOW: 1901 Corporate Centre Dr - Oceanside, CA 92056 | 1(800)990-0905

Technical Support: 1(800) 959-9226 | Email: moreinfo@magnaflow.com

INSTALLATION INSTRUCTIONS



Step 1: To remove the OEM system first unplug the electrical connector at the vehicles exhaust valve located at the rear muffler. Using a T47 Torq socket remove the cross brace. Next unbolt the mounting bracket at the exhaust inlet. Loosen the clamp at the exhaust inlet. Remove all welded hangers from the rubber insulators. The complete OEM exhaust may now be removed. Once the exhaust is off the vehicle break the tack weld securing the inlet clamp to the inlet pipe and remove. Unbolt the Exhaust valve motor from the muffler assembly. Be sure to retain all mounting hardware as it will be needed to install your new MAGNAFLOW system

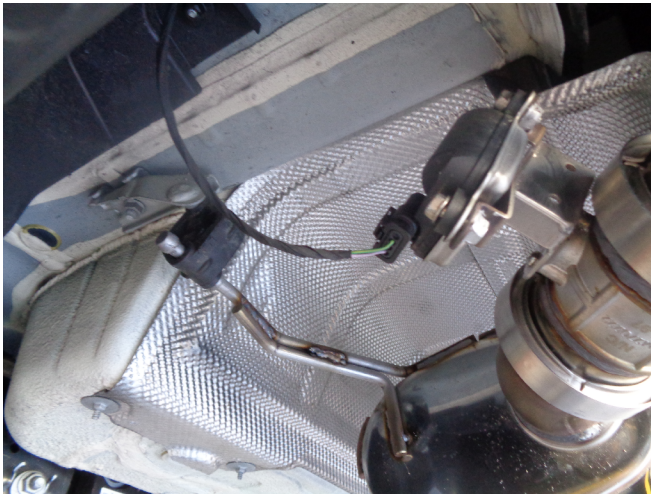

Step 2: Before installing your new system attach the OE valve motor to the valve on the Magnaflow Muffler Assembly using the OE hardware.

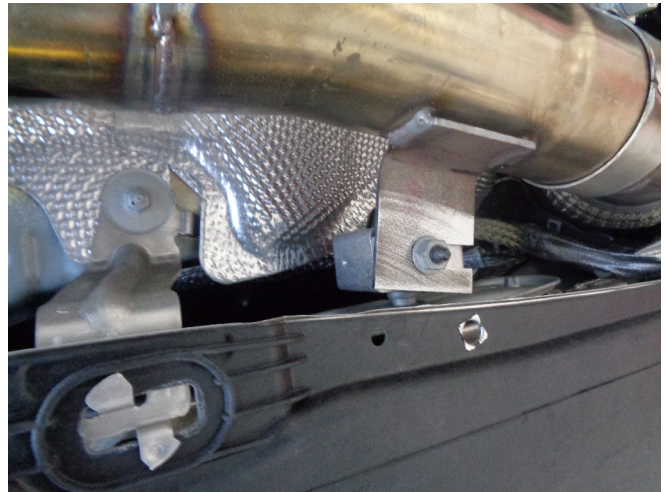

Step 3: Begin the installation process by loosely attaching the Inlet Pipe Assembly to the catalytic converter outlet using the clamp you removed from the OE system. Locate the hanger bracket to the OE hanger location and loosely secure using the OE hardware.

INSTALLATION INSTRUCTIONS



Step 4: Loosely attach the Resonator Assembly Inlet to the Inlet Pipe Assembly outlet with the supplied clamp. Install the Extension Pipe to the Resonator Assembly the same way.

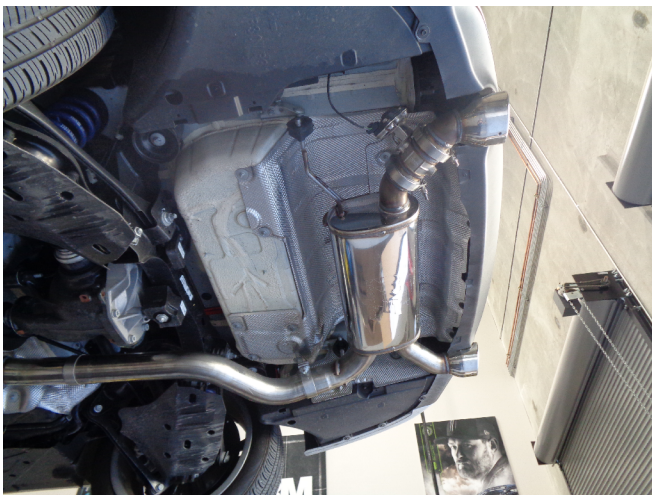

Step 5: Install the Muffler Assembly by attaching the inlet to the Extension Pipe. Loosely secure using the supplied clamp. Locate both welded hangers to the OE rubber insulators. Reattach the electrical connector plug to the valve motor and reinstall the cross member.



Step 6: Once a final position has been chosen for the new exhaust system, evenly tighten all clamps from front to rear using the torque specifications on page one of these instructions. Inspect all fasteners after 25-50 miles for operation and re-tighten if necessary.