

2011-2015 Ford F-Series 6.7L Diesel

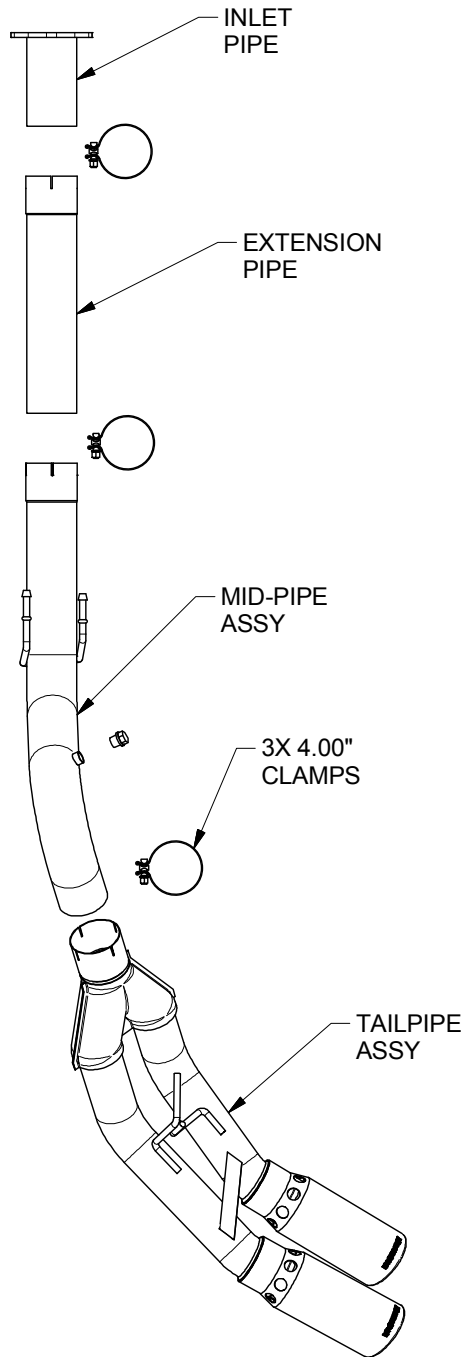

Warning When working on, under, or around any vehicle exercise caution. Please allow the vehicle's exhaust system to cool before removal, as exhaust system temperatures may cause severe burns. If working without a lift, always consult vehicle manual for correct lifting specifications. Always wear safety glasses and ensure a safe work area. Serious injury or death could occur if safety measures are not followed.

Step 1: Begin by unfastening the OEM exhaust from the Diesel Particulate Filter (DPF) at the 3 bolt flange and remove the EGT sensor (Removing the EGT sensor only applies to 2015 vehicles, 2011-2014 vehicles do not have EGT sensors). You can now disengage the welded hangers from the rubber insulators and remove the exhaust system from the vehicle. Do not damage the OEM rubber insulators, as they will be reused to mount the new system. You may also cut the tailpipe behind the muffler to aid in removal of the system.

Step 2: Install the flanged inlet pipe to the catalytic converter outlet. Crew Cab and Long Bed (CC/LB) models require the 19" Extension Pipe, shorter vehicles will now use the Muffler Assembly and appropriate clamps. Leave all clamps loose for final adjustment of the complete system. Install the Tail Pipe Assembly in a similar fashion using the supplied 4.00" clamps and by fitting the welded hangers into the rubber insulators. Re-install the EGT sensor. If the vehicle is a 2011-2014 model year install the supplied plug into the sensor boss located on the Mid-Pipe Assembly.

Step 3: With all components mounted loosely, adjust the system for overall aesthetics and clearance of frame & bodywork. (MAGNAFLOW recommends at least 1/2" of clearance between the exhaust system and any body panels to prevent heat-related body damage or fire.)

Step 4: Once a final position has been chosen for the new system, evenly tighten all fasteners from front to rear. The supplied band clamps must be VERY tight to properly align the pipes and prevent leaks (Approximately 40ft-lbs). U-bolt clamps should be tightened to approximately 30-35ft-lbs. Inspect all fasteners after 25-50 miles of operation and re-tighten if necessary.

**** Magnaflow Performance Exhaust recommends professional installation on all their products**