

2007 GM SILVERADO/SIERRA 2500 HD - V8 6.0L, CREW CAB

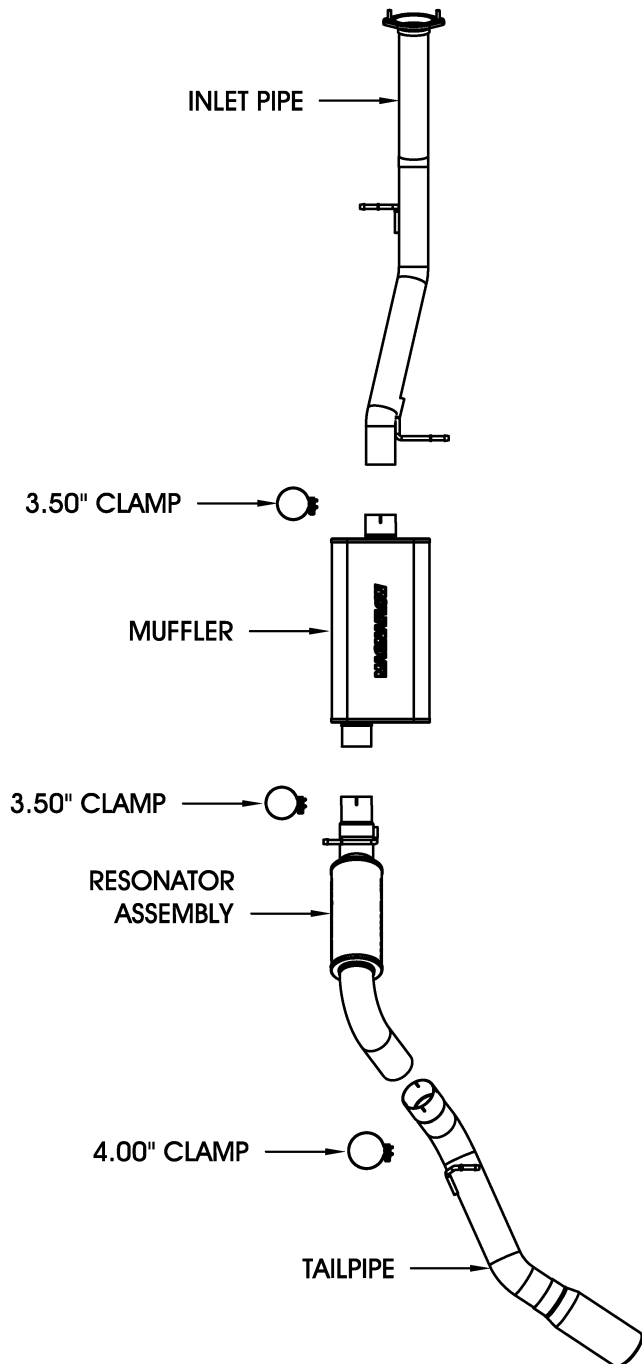

Warning: When working on, under, or around any vehicle exercise caution. Please allow the vehicle's exhaust system to cool before removal, as exhaust system temperatures may cause severe burns. If working without a lift, always consult vehicle manual for correct lifting specifications. Always wear safety glasses and ensure a safe work area. Serious injury or death could occur if safety measures are not followed.

Step 1: (Carefully read all instructions before installation) Disconnect the vehicle's battery before removal of the OEM exhaust. This will allow the computer to reset itself with the new system, and prevent electrical accidents. To remove the OEM exhaust system, you will first need to cut the pipe behind the muffler before it goes over the axle. You can then disengage the welded hangers from the rubber insulators and remove the tailpipe. Unbolt the muffler inlet from the catalytic converter at the 2-bolt flange. Do not damage or discard the OEM fasteners or rubber insulators, as they will be reused to mount the new system. Disengage the muffler hangers and remove it from the vehicle.

Step 2: Install the new intermediate pipe at the 2-bolt flange using the OEM fasteners. Leave all clamps and fasteners loose for final adjustment of the complete system. Install the muffler and resonator assembly using the supplied 3.50" clamps and by fitting the welded hangers into the OEM rubber insulators. Install the tailpipe assembly in a similar fashion using the supplied 4.00" clamp.

Step 3: With all components mounted loosely, adjust the system for overall aesthetics and clearance of frame & bodywork. (MAGNAFLOW recommends at least 1/2" of clearance between the exhaust system and any body panels to prevent heat-related body damage or fire.)

Step 4: Once a final position has been chosen for the new system, evenly tighten all fasteners from front to rear. The supplied band clamps must be VERY tight to properly align the pipes and prevent leaks (Approximately 40ft-lbs). U-bolt clamps should be tightened to approximately 30-35ft-lbs. Inspect all fasteners after 25-50 miles of operation and retighten if necessary.

*MAGNAFLOW Performance Exhaust recommends professional installation on all their products

Technical support: 1-800-959-9226 ext. 4500

MAGNAFLOW Performance Exhaust - 22961 Arroyo Vista - Rancho Santa Margarita, CA 92688