



## **BXW4070 & BXW4071** TrackPro & 2-Point Long L Bracket Kits Installation Instructions



TrackPro & 2-Point Long L Brackets

BXW4070 & BXW4071  
TrackPro & 2-Point Long L Bracket Kits  
Installation Instructions

## BXW4071 Kit, Long L Bracket Pair Installation

1. Install the weight distribution hitch per manufacturer's instructions.
2. For TrackPro hitches measure 20"-25" back from the center of the ball coupler and mark this point on the trailer tongue frame on both sides. For 2-Point hitches measure 24"-27" back from the center of the ball coupler and mark this point on the trailer tongue frame on both sides. Center the L bracket mounting holes on the backing plate over the marked area so that the offset is towards the front of the trailer on each side. Both backing plates should be an equal distance from the ball coupler. Remove or relocate any obstructions on the trailer tongue framework if necessary. Finger tighten the bolts on the backing plates at this time.
3. The end of the spring bar should be a minimum of 4" from the center of the L bracket backing plate to the open end of the bar. After verifying that the L brackets are 20"-25" for TrackPro and 24"-27" for 2-Point hitches from the center of the coupler, fully tighten the 1/2" hex head bolts against the trailer tongue framework. (Figure 2) **(Do NOT use Loctite® Red)**
4. Install L brackets onto backing plate by inserting the two (2) 1/2" whiz flange bolts leaving the top hole open on the L bracket. Apply Blue Loctite to the threads and torque bolts 78 ft/lbs.

**Repeat on other side of the trailer**

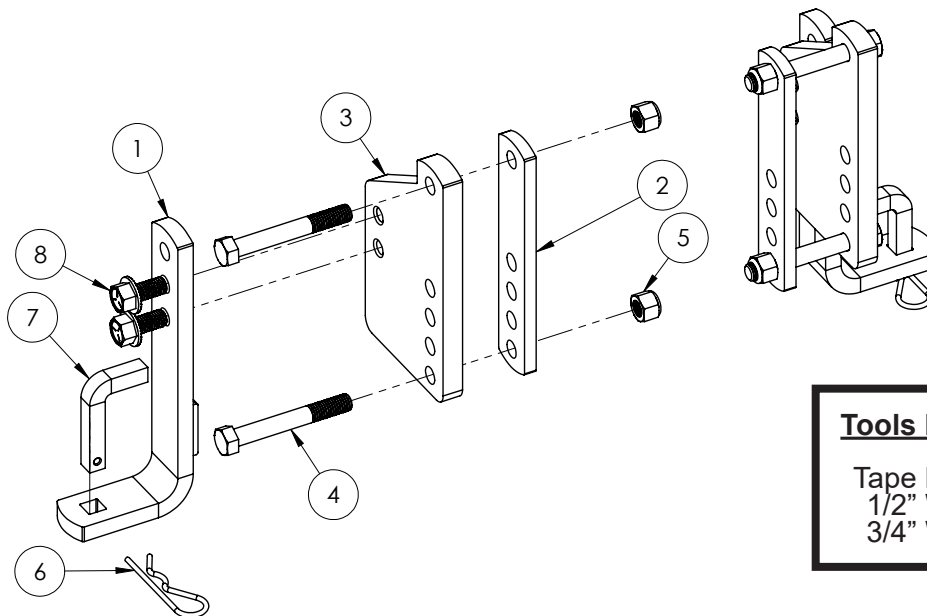

**Tools Required**

Tape Measure  
1/2" Wrench  
3/4" Wrench

Item No.	Part No.	Description	Qty.
1.....	61-8492 .....	Long L Bracket Plate .....	2
2.....	101-10549 .....	Backing Plate .....	2
3.....	101-10677 .....	Off-set L Bracket Mounting Plate.....	2
4.....	201-0851 .....	1/2"-13 x 3-3/4" Hex Head Bolt, Grade 5, ZP .....	4
5.....	202-0094 .....	1/2"-13 Hex Nylon Insert Lock Nut, ZP .....	4
6.....	220-0069 .....	9/64" x 3-3/8" Reusable Cotter Pin, ZP .....	2
7.....	299-0856 .....	1/2" Retaining Key.....	2
8.....	201-1014 .....	1/2"-13 x 1" Whiz Flange Bolt.....	4

BXW4070 & BXW4071  
TrackPro & 2-Point Long L Bracket Kits  
Installation Instructions

## BXW4070 Kit, Long L Bracket, Single

1. Install the weight distribution hitch per manufacturer's instructions.
2. For TrackPro hitches measure 20"-25" back from the center of the ball coupler and mark this point on the trailer tongue frame on both sides. For 2-Point hitches measure 24"-27" back from the center of the ball coupler and mark this point on the trailer tongue frame on both sides. Center the L bracket mounting holes on the backing plate over the marked area so that the offset is towards the front of the trailer on each side. Both backing plates should be an equal distance from the ball coupler. Remove or relocate any obstructions on the trailer tongue framework if necessary. Finger tighten the bolts on the backing plates at this time.
3. The end of the spring bar should be a minimum of 4" from the center of the L bracket backing plate to the open end of the bar. After verifying that the L brackets are 20"-25" for TrackPro and 24"-27" for 2-Point hitches from the center of the coupler, fully tighten the 1/2" hex head bolts against the trailer tongue framework. (Figure 2) (**Do NOT use Loctite® Red**)
4. Install L brackets onto backing plate by inserting the two (2) 1/2" whiz flange bolts leaving the top hole open on the L bracket. Apply Blue Loctite to the threads and torque bolts 78 ft/lbs.

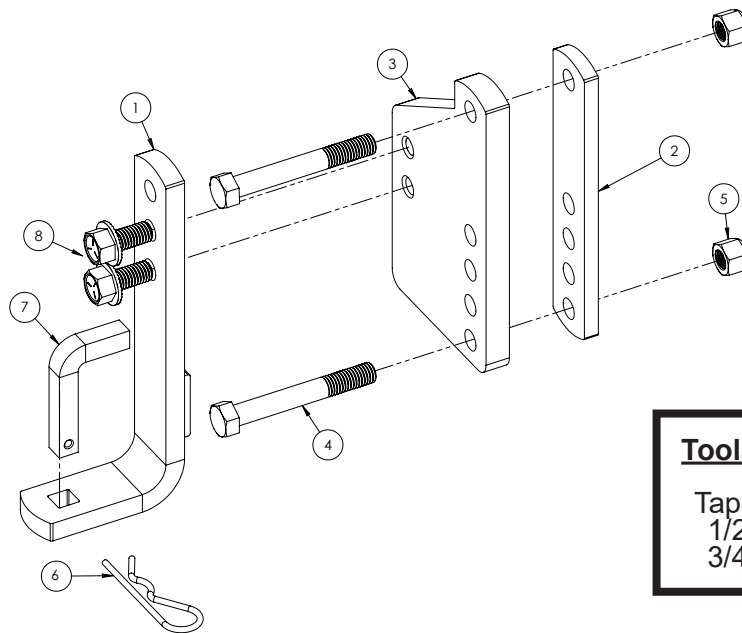

**Tools Required**

Tape Measure  
1/2" Wrench  
3/4" Wrench

Item No.	Part No.	Description	Qty.
1.....	61-8492 .....	Long L Bracket Plate .....	1
2.....	101-10549 .....	Backing Plate .....	1
3.....	101-10677 .....	Off-set L Bracket Mounting Plate.....	1
4.....	201-0851 .....	1/2"-13 x 3-3/4" Hex Head Bolt, Grade 5, ZP .....	2
5.....	202-0094 .....	1/2"-13 Hex Nylon Insert Lock Nut, ZP.....	2
6.....	220-0069 .....	9/64" x 3-3/8" Reusable Cotter Pin, ZP .....	1
7.....	299-0856 .....	1/2" Retaining Key.....	1
8.....	201-1014 .....	1/2"-13 x 1" Whiz Flange Bolt.....	2

BXW4070 & BXW4071  
TrackPro & 2-Point Long L Bracket Kits  
Installation Instructions

**CUSTOMER SERVICE COMMITMENT**

Blue Ox® is committed to providing you with exceptional customer care throughout your lifetime with our products. Our team is here to assist you with any questions you may have regarding the performance of your product. Simply call (402) 385-3051 and you can speak with our customer care team.

Additionally, please visit our website to see which rallies our Destination America team will be attending. For a nominal fee, our service technician will service your towing system to ensure it's in proper working condition. Also, as a commitment to our customers, should you visit our factory, you can stay at our full service Blue Ox® campground at no charge along with enjoying a factory tour.

Again, thank you for being our customer and for the confidence you have shown in the performance of our products. It is because of customers like you we enjoy the success we have today.



© 2013 Blue Ox  
One Mill Road, Industrial Park  
Pender, Nebraska 68047  
Phone: (402) 385-3051  
Fax: (402) 385-3360  
[www.blueox.com](http://www.blueox.com)