



BLUE OX®

Baseplate Installation Instructions

BX1655

2004-05 Chevrolet Malibu
(Includes MAXX)

Installation Instructions

Serial Number

Please read BOTH these Installation Instructions and the General Instructions before attempting to install or operate this equipment.

- Blue Ox® towing products and accessories are intended to be installed by Blue Ox® Dealers who are familiar with our products and have the equipment and knowledge to do "fit work". When necessary Blue Ox® Dealers can be found at www.blueox.com or by contacting our Customer Care Department at (402) 385-3051.
- Many Blue Ox® Baseplates are designed to use existing holes and hardware to mount the baseplate to the towed vehicle. Even though bolts are there, do not assume they are adequate for baseplate mounting. Always use hardware supplied in the hardware kit or existing hardware specified in the Baseplate Towing Installation Instructions.

Attachment Tab Height: 13.5"

Attachment Tab Width: 23.5"

Bolt Torque Specifications

Torque in Foot-Pounds for Metric Bolts

Bolt Size	Grade 8.8	Grade 10.9
6MM	6	8
8MM	16	22
10MM	31	40
12MM	54	70
14MM	89	117

Confirm the towability and pre-towing procedures for your vehicle with the owner's manual or contact the vehicle's manufacturer for specific towing procedures.

Bolt Torque Specifications

Torque in Foot-Pounds for Inch Bolts

Bolt Size	Grade 5	Grade 8
1/4"	10	14
5/16"	19	29
3/8"	33	47
7/16"	54	78
1/2"	78	119
5/8"	154	230



If the front of your vehicle looks different than this, call us at (888) 425-5382.

! WARNING

Failure to read and follow these instructions could result in separation of the towed vehicle from the tow bar, causing property damage, loss of towed vehicle, personal injury or death.

BX1655

2004-05 Chevrolet Malibu

(Includes MAXX)

Installation Instructions

Parts List

Ref. No.	Qty.	Part #	Description
1	1	61-5975	Weldment, Baseplate, BX1655
2	3	61-5208	3/8" Nutplate, with Wire
3	7	201-0368	3/8-16x1 1/2" Hex Bolt, Grd. 5, ZP
4	7	203-0010	3/8" Lock Washer, ZP
5	4	202-0003	3/8-16 Hex Nut
6	2	201-0979	#12-14 x 1" Self Drilling Screw, ZP
7	2	202-0047	#10-32 Hex Nut
8	2	203-0054	#10 Lock Washer
9	2	201-0192	#10-32x1/2" Slot. Rd. Hd. Screw
10	2	101-5822	Adapter, 4 Way Connector
11	2	62-3468	Attachment, Assembly, SF/SB (R)
	2	290-0437	Cap Plug, Black (Not Shown)
	2	226-0046	Baseplate Safety Cable, 36" CL III (NS)
	4	229-0359	Quicklink, 3/8, ZP (Not Shown)

Tools Required

10MM Socket	Phillips Screwdriver
9/16" Socket	Utility Knife
13/32" Drill Bit	Vise Grips
1/4" Drill Bit	Loctite® RED

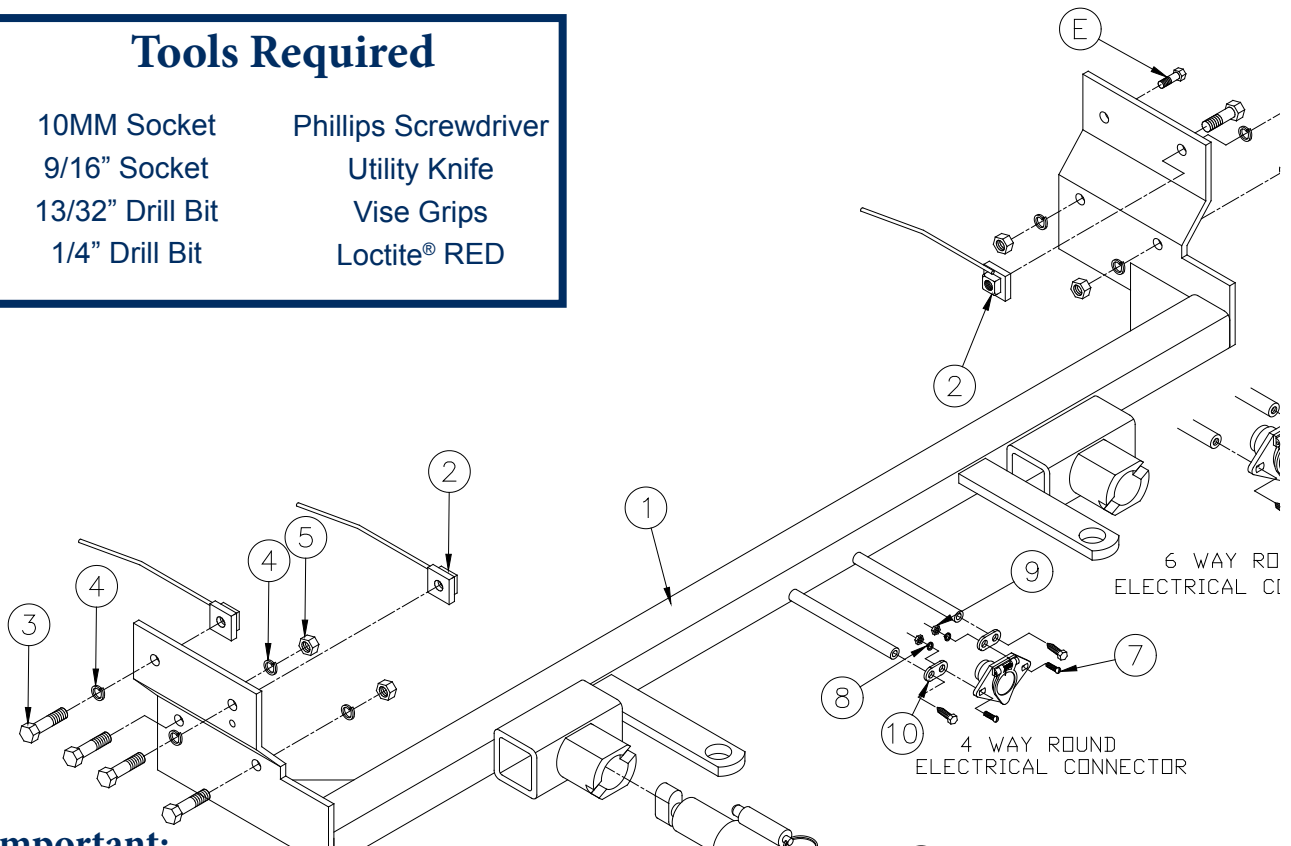

Important:

Use only genuine factory replacement parts on your baseplate. Do **NOT** substitute homemade or non-typical parts. If a bolt is lost or in need of replacement, for your safety and the preservation of your baseplate, be sure to use a replacement bolt of the same grade (In most cases it will be Grade 5, please reference the parts list above). Replacement parts may be ordered through your nearest Blue Ox® Dealer or Distributor. Failing to follow and/or altering these installation instructions in either installation or required equipment will void the manufacturer's warranty. Towing behind a non-motorized vehicle will void the warranty.

BX1655
2004-05 Chevrolet Malibu
(Includes MAXX)
Installation Instructions

Attachment Tabs:

Due to the design of the removable tabs, the RangeFinder II, Adventurer and Ambassador tow bars can not be used. Adapters, except the BX8833 and BX88151, can not be used with this baseplate.

Instructions:

The headlight assemblies, front fascia, horn bracket and air baffle are removed and reinstalled for the baseplate installation. Drilling is required. Trimming of the air dam is required.

The dimensional variations between otherwise identical vehicles can be considerable. While the baseplate was designed for easy installation, it may be necessary to tailor the baseplate slightly to compensate for auto manufacturer's tolerances. These minor adjustments may include filing a hole slightly, bending electrical rods or bending end plates.

The Bx8869 Bulb and Socket Wiring Kit is recommended for this vehicle.



Installation Instructions:



1. Remove the four Phillips head pushpins from the black plastic cover on the top side of the fascia. Set the pushpins aside to be reinstalled later.



2. Using a 10MM socket, remove two metric bolts from the headlight assembly. Pull the headlight assembly forward, unplug the electrical connections. Set the headlight assembly and the metric bolts aside to be reinstalled later. Do this to both sides of the vehicle.

Handling of some cosmetic parts when installing this product may require the use of protective covers, rags, specialty tools, etc. to prevent damage.

BX1655
2004-05 Chevrolet Malibu
(Includes MAXX)
Installation Instructions



3. Using a 10MM socket, loosen one metric bolt (**DO NOT REMOVE**), just behind the headlight assembly. Do this to both sides of the vehicle.



4. Remove two pushpins from forward of the front tires, on the edge of the wheel well and the fascia. There are four pushpins to remove. Set the pushpins aside to be reinstalled later. Do this to both sides of the vehicle.



5. Using a 10MM socket, remove one metric bolt from just forward of the front tire, on the fascia's corner. Set the bolt aside to be reinstalled later. Do this to both sides of the vehicle.



6. Remove two pushpins from the grille opening on the bottom side of the metal bumper and four metric bolts from the bottom edge of the fascia. Do this to both sides of the vehicle. Pull fascia forward and set aside carefully to be reinstalled later. Set the bolts aside to be reinstalled later.



7. Using the 10MM socket, remove the metric bolt for the horn bracket on the driver's side, unplug the electrical connections. Set the bolts and the horn bracket aside to be reinstalled later.

BX1655
2004-05 Chevrolet Malibu
(Includes MAXX)
Installation Instructions



8. Remove two pushpins from the air baffle on the passenger's side and using a 10MM socket, one metric bolt behind the wheel well. Set pushpins and bolt aside to be reinstalled later.



9. Remove one pushpin from the lower plastic on the bottom rib of the frame and pull plastic down to expose the bottom of the frame. Set pushpin aside to be reinstalled later. Do this to both sides of the vehicle.



10. Using the utility knife, trim the air dam 2 1/2" below the metal bumper to open the area for the baseplate. Do this to both sides of the vehicle.

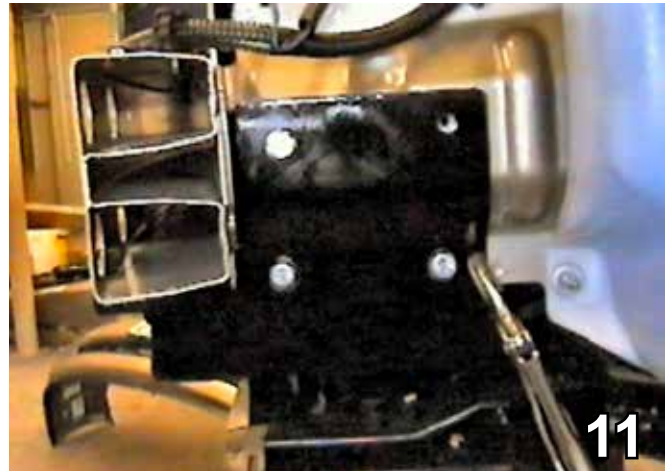

11. Align the upper back baseplate hole with the horn bracket mounting hole on the driver's side and clamp the baseplate in place with the vise grips. Measure driver's side height on frame and the distance from the back of metal bumper, clamp passenger's side to the same locations on the frame.

BX1655
2004-05 Chevrolet Malibu
(Includes MAXX)
Installation Instructions



12. Using the baseplate as a template, drill the four holes on the passenger's side and three holes on the driver's side with the 13/32" drill bit.

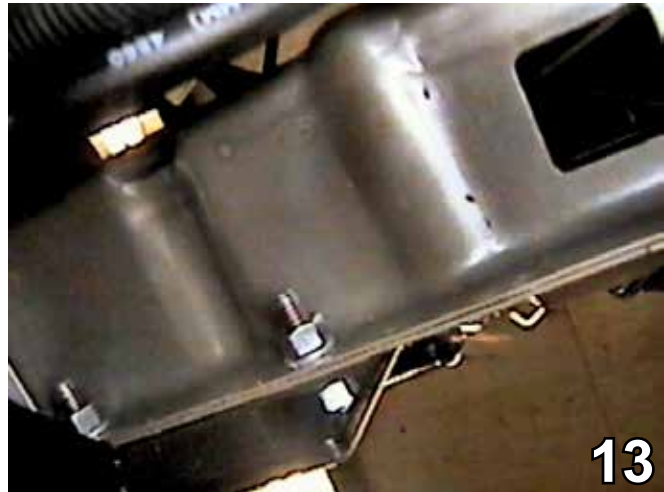

13. Insert two 3/8" bolts into the lower holes in the baseplate. Tighten the lock washer and the hex nut. Do this to both sides of the vehicle.

BE SURE TO USE LOCTITE® RED ON ALL BOLTS BEFORE TIGHTENING. TIGHTEN ALL BOLTS ACCORDING TO THE TORQUE CHART ON THE FRONT PAGE OF THESE INSTRUCTIONS OR ON PAGE 3 OF THE BASEPLATE GENERAL TOWING INSTRUCTIONS.



14. Insert the nutplate into the opening on the bottom of the frame (see photo 13) to align with the upper drilled hole on the driver's side, tighten the lock washer and hex nut.

16. Reinstall the horn bracket with existing metric bolts on the driver's side and the air baffle on the passenger's side with the existing bolt and pushpins (the front push pin will go in the drilled hole created in step 15). Be sure all electrical connections are plugged in properly.

Install the tow bar and safety cables according to the instructions included in their packages.

Do Not substitute other devices if the tow bar pin and clip are lost.

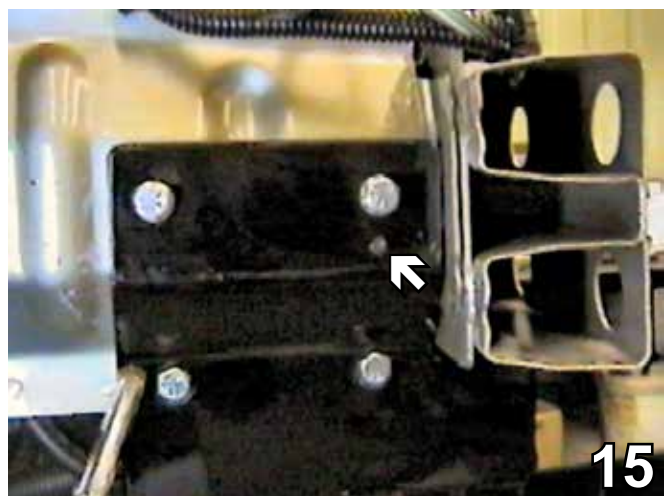

15. Insert the nutplate into the opening on the bottom of the frame to align with the upper drilled holes on the passenger's side, tighten the lock washer and the hex nut. Using the baseplate as a template, drill the hole on the passenger's side with the 1/4" drill bit (see the arrow in the photo above).

When using power drills be aware of the dangers of torque and drill bit length.

BX1655
2004-05 Chevrolet Malibu
(Includes MAXX)
Installation Instructions

DEALER or INSTALLER:

Be certain the user receives the instructions sheets for their products.

CUSTOMER SERVICE COMMITMENT



Shown without removable tabs



Shown with removable tabs installed

Blue Ox is committed to providing you with exceptional customer care throughout your lifetime with our products. Our team is here to assist you with any questions you may have regarding the performance of your product. Simply call (402) 385-3051 and you can speak with our customer care team.

Additionally, please visit our website to see which rallies our Destination America team will be attending. For a nominal fee, our service technician will service your towing system to ensure it's in proper working condition. Also as a commitment to our customers, should you visit our factory you can stay at our full service Blue Ox campground at no charge along with enjoying a factory tour.

Again thank you for being our customer and for the confidence you have shown in the performance of our products. It is because of customers like you we enjoy the success we have today.

If the baseplate is in an accident, it must be replaced. DO NOT use it again! An accident can cause unseen damage and using it again could result in more damage or serious injury. DO NOT use the baseplate if it is damaged or missing parts.



© 2006, 07, 09, 10 Blue Ox
One Mill Road, Industrial Park
Pender, Nebraska 68047
Phone: (402) 385-3051
Fax: (402) 385-3360
www.blueox.com
5/19/10

General Information

1. Ensure that your product(s) are registered online at www.blueox.com. It is crucial to register your product(s) so that you may be alerted of product offerings, updates, upgrades, maintenance and safety bulletins, and/or recalls.
2. **It is the owner's responsibility to inspect all towing equipment for cracked welds, missing or worn parts and loose bolts before each towing trip.** Be sure to use Loctite® Red on all bolts and tighten to the recommended specifications.
3. **It is the owner's responsibility to hook up all towing equipment per manufacturer's instructions/recommendations.**
4. Remove the attachment tabs when not in use (if applicable).

Notice To Baseplate Installer

1. It is YOUR responsibility to watch for:

- Oil cooler and air conditioner lines
- Electrical wires and hoses
- Missing parts or attaching points on the frame

** If the baseplate is improperly installed and is against a wire or hose, it could cause fluid leaks or electrical shorts some time after the actual baseplate installation.

Permanent Baseplate Safety Cable Installation

Permanent baseplate safety cables are strongly recommended when towing a vehicle with a tow bar. The principle function of the permanent baseplate safety cables is to prevent the towed vehicle from breaking loose in the event the connection between the frame of the towed vehicle and the baseplate fails or becomes disconnected. The cables must be connected from the baseplate to the frame rail or cross member of the vehicle's frame. The illustrations below show the possible arrangements recommended by Blue Ox®. Each permanent baseplate safety cable must have an adequate weight rating for the towing system. The weight rating of the two (2) cables together will not qualify.

Do not mount the permanent baseplate safety cables against wires, hoses or brake lines.

These permanent baseplate safety cables should remain installed as long as the baseplate is installed on the vehicle. Permanent baseplate safety cables are to be used in conjunction with, and NOT a replacement for legally required safety cables attaching the towed vehicle to the towing vehicle.

OPTION #1

Permanent Baseplate Safety Cables to Cross Member or Frame of Towed Vehicle.

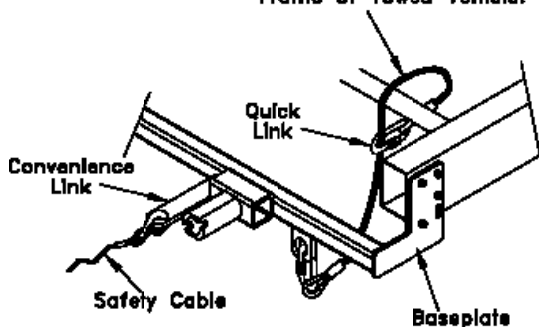

OPTION #2

Permanent Baseplate Safety Cables to Cross Member or Frame of Towed Vehicle.

